

FILE NO.

SERVICE MANUAL LCD Television

Model No. LCD-32XH4

(Argentina)

Service Ref. No. LCD-32XH4-00



Contents

Safety Notice	2
Specifications	3
Chassis Block Diagrams	4-5
IC Block Diagrams	6-11
On-screen Service Menu System	12-17
Service Adjustments	18
Mechanical Disassembly	19-24
Cabinet Parts List	25
Chassis Electrical Parts List	27-38
Printed Wiring Board	39-45

Product Code:113011416

Original Version

Chassis Series: UH2-L

Give complete "SERVICE REF. NO." for parts order or servicing. It is shown on the rating label at the cabinet back of the unit.

This T.V. receiver will not work properly in foreign countries where the television transmission system and power source differ from the design specifications. Refer to the specification table.

Safety Notice

Safety Precautions

The following precautions must be observed.



- 1: Comply with all caution and safety-related notes provided on the cabinet back, cabinet bottom, inside the cabinet or on the chassis.
- 2: When replacing a chassis in the cabinet, always be certain that all the protective devices are installed properly, such as, control knobs, adjustment covers or shields, barriers, etc..

DO NOT OPERATE THIS TELEVISION WITHOUT THE PROTECTIVE SHIELD IN POSITION AND PROPERLY SECURED.

- 3: Before replacing the cabinet cover, thoroughly inspect the inside of the cabinet to see that no stray parts or tools have been left inside.

Before returning any television to the customer, the service personnel must be sure that it is completely safe to operate without danger of electrical shock.

Product Safety Notice

Product safety should be considered when a component replacement is made in any area of a receiver. Components indicated by mark  in the parts list and the schematic diagram designate components in which safety can be of special significance. It is particularly recommended that only parts designated on the parts list in this manual be used for component replacement designated by mark . No deviations from resistance wattage or voltage ratings may be made for replacement items designated by mark .

Specifications

Power Source AC 100 - 240 Volts, 50/60Hz

Receiving System PAL-N/N, PAL-M/M, NTSC-M/M

Channel Coverage ANTENNA mode
VHF: CH02 - CH13
UHF: CH14 - CH69
CATV mode
VHF band: CH01-CH13
MID band: CH14-CH22
SUPER band: CH23-CH36
HYPER band: CH37-CH64
ULTRA band: CH65-CH94 and CH100-CH125
Low MID band: CH95-CH99

Aerial Input Impedance 75 Ω

LCD Panel

Screen Size (Measured Diagonally): 32 inches

Picture Resolution: WXGA 1366 (Horiz.) x 768 (Vert.) pixels

Brightness: 500 cd/m²

Audio Output (RMS) 9 W + 9 W

Speaker Size 6 cm x12 cm x 2 pcs

Input and Output Terminals

AV1 Input Video Input: Composite video Input (RCA Jack) x1
S-Video Input: DIN 4-pin Jack x1
Audio Input: L/R Stereo Input (RCA Jack) x 1 set

AV2 Input Video Input: Component Y (combined with composite video input), C_B, C_R Input (RCA Jack) x1 set
Audio: L/R Stereo Input (RCA Jack) x 1 set

HDMI Input HDMI Terminal 19 pin x1

PC Input Video Input: D-SUB 15 pin x1
Audio Input: Mini stereo jack x 1

Output Terminals Video Monitor Output: RCA jack x 1
Audio Monitor Output: L/R Stereo Output (RCA jack) x 1 set
Headphone Jack : Mini stereo jack x1

Dimensions 818 X 624 X 270 mm (including stand)

Weight <14.3kg (Including Stand)

Environmental Considerations

Operating Temperature 0°C ~ 40°C (32°F ~ 104°F)

Operating Humidity 20 ~ 80%

Storage Temperature -10°C ~ 50°C (14°F ~ 122°F)

Storage Humidity 20 ~ 80%

Specifications subject to change without notice.

Chassis Block Diagram

POWER SUPPLY IC (STRW6753)

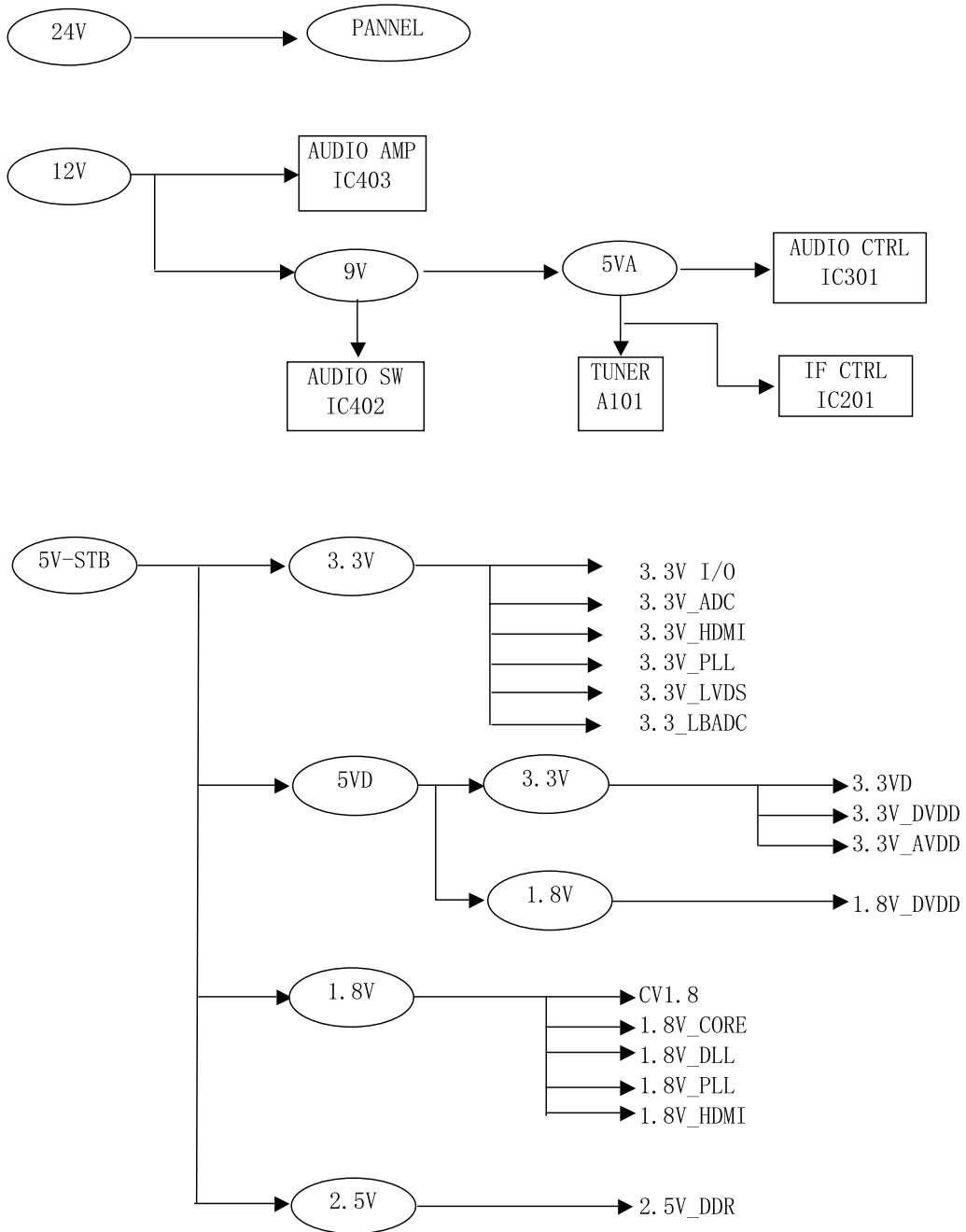
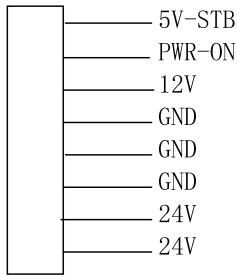

IC Block Diagrams (On the ASSY, PWB, MAIN)

IC003 < Sync. Separation> LA7217

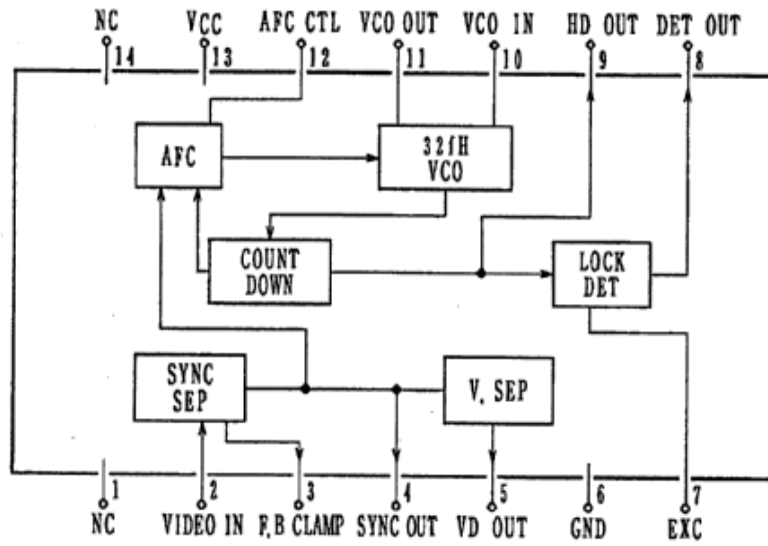

IC402

QTC4052BF---P

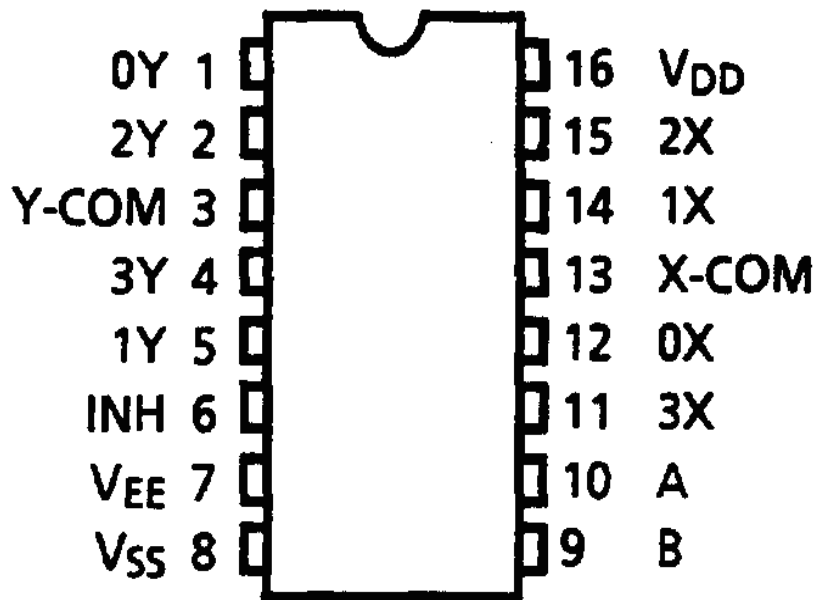

IC Block Diagrams (On the ASSY, PWB, MAIN)

IC301

LV1116

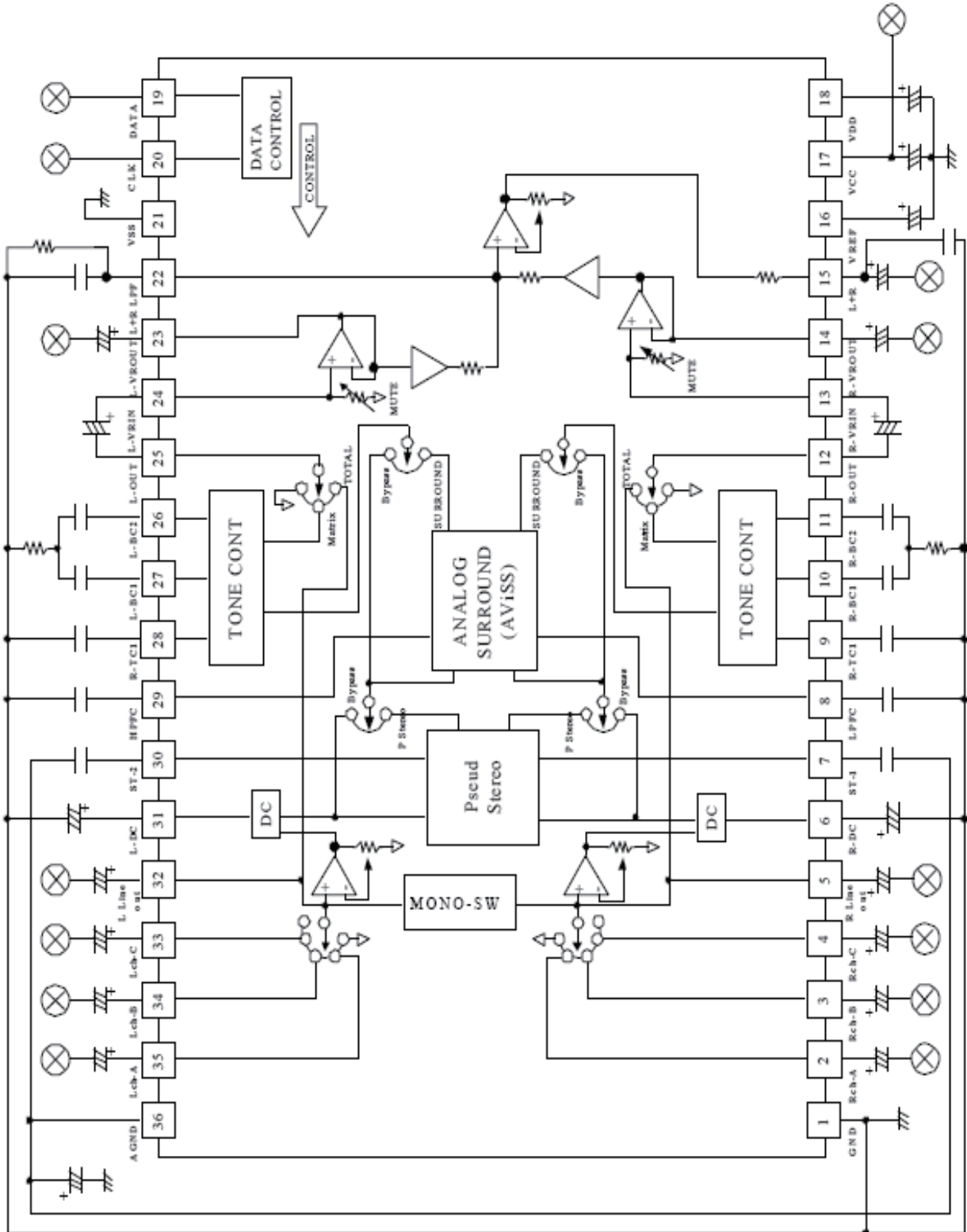

IC Block Diagrams (On the ASSY, PWB, MAIN)

IC7300 QXXAVC914---M

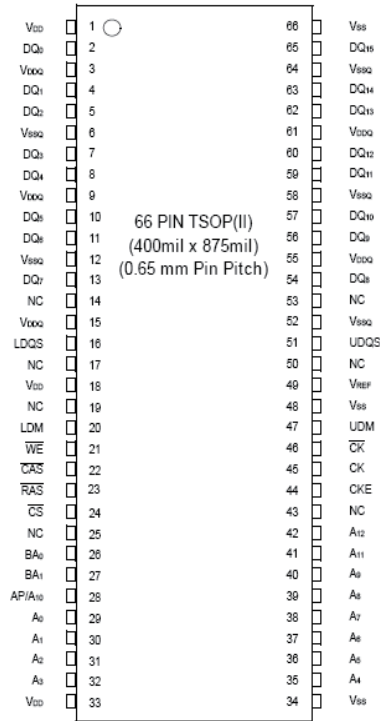

IC7500 QANX9011L---M

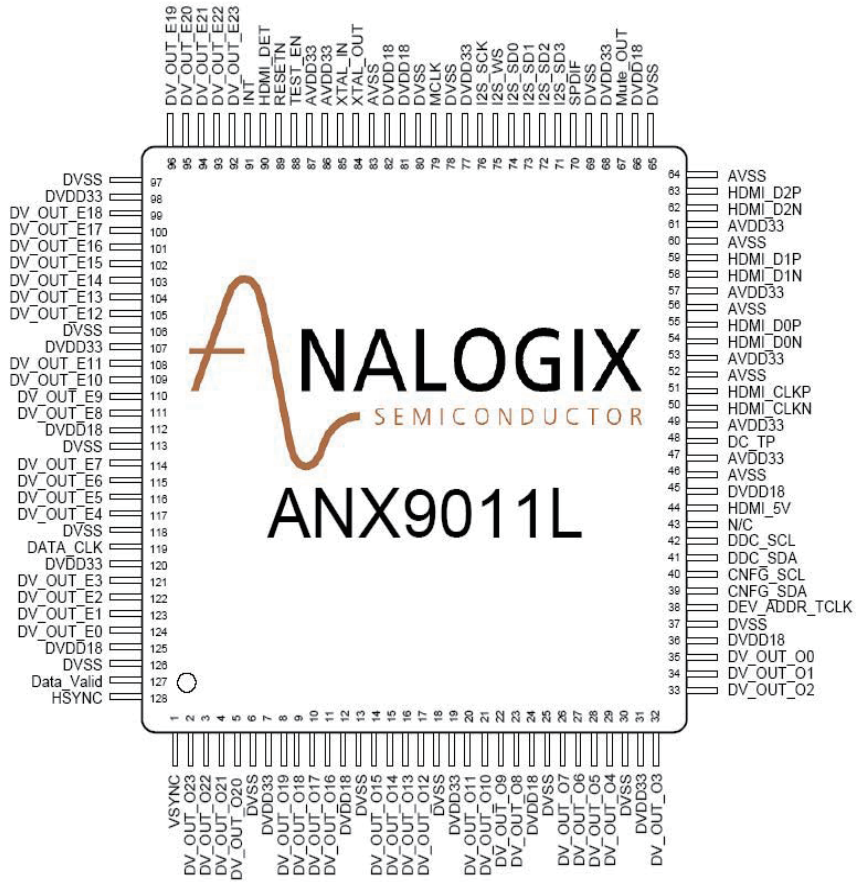

IC Block Diagrams (On the ASSY, PWB, POWER)

IC601 VIPER53

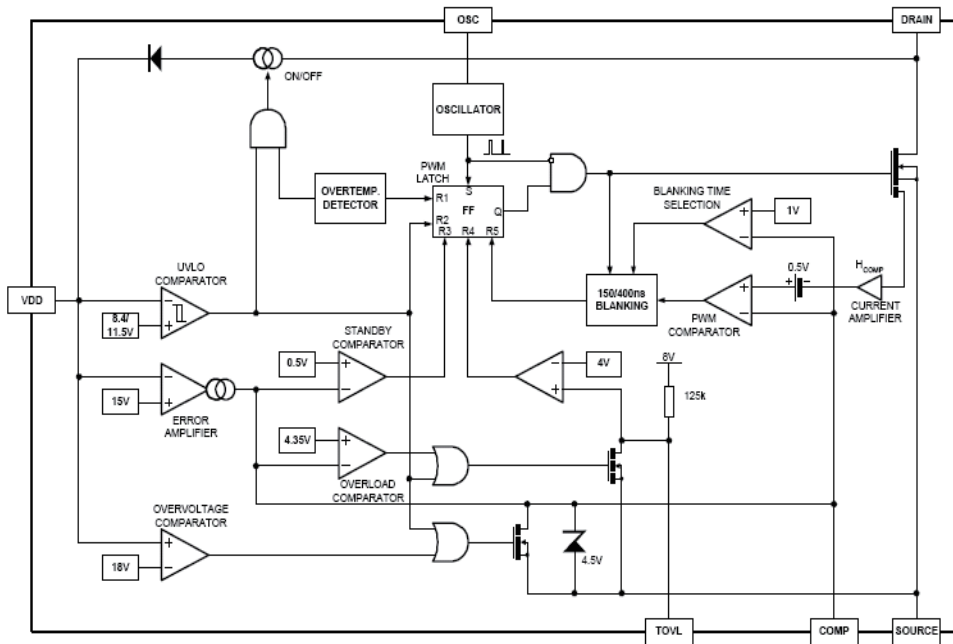

IC602 L6563

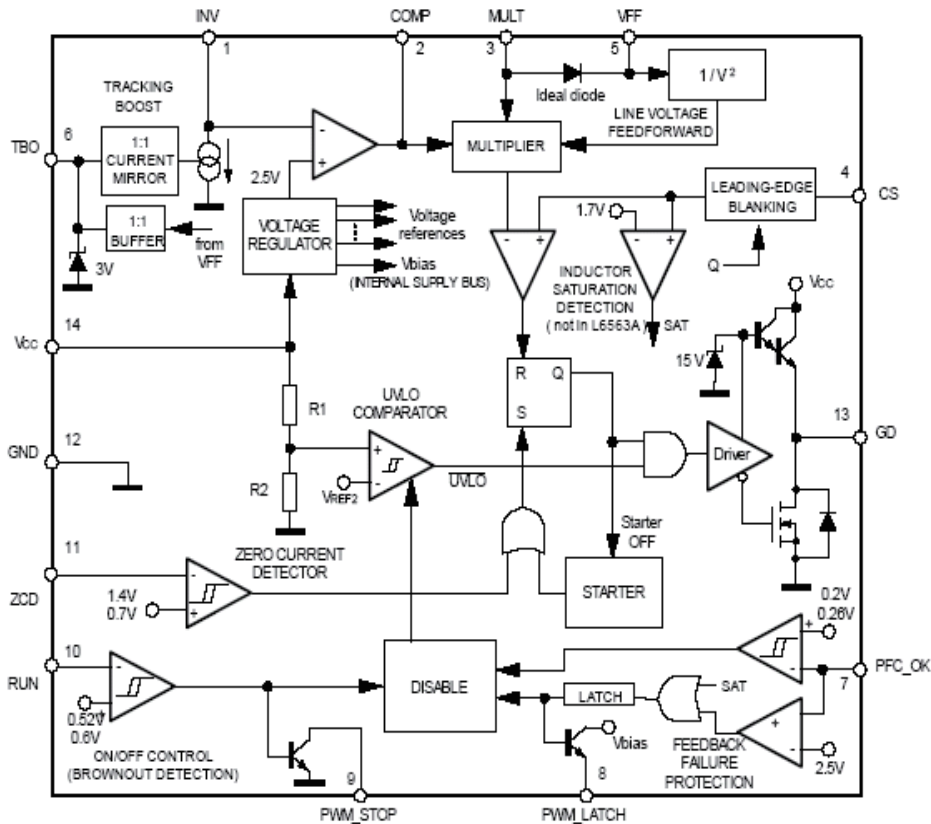

IC Block Diagrams (On the ASSY, PWB, POWER)

IC603 L6599TR

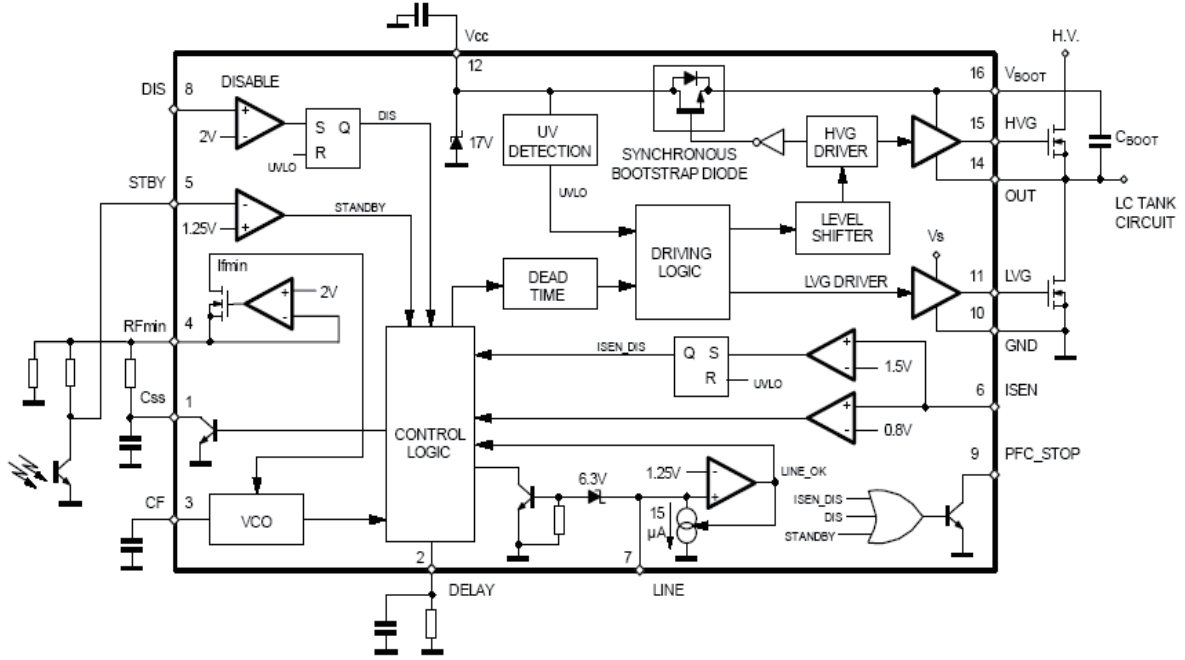

IC608 LM393

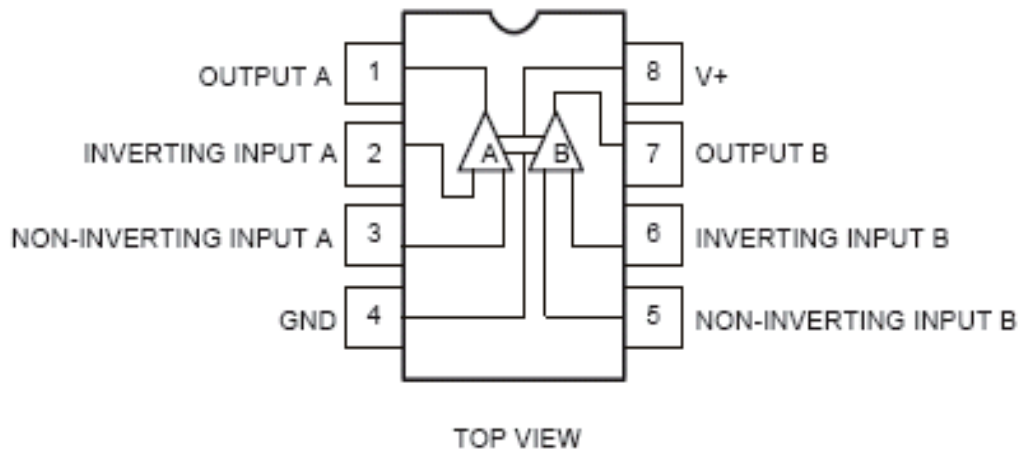

On-screen Service Menu System

General

This set has an **On-screen Service Menu System** included in the CPU that allows remote operation for most of the service adjustments.

On-screen Service Menu System

Quick operation is needed to enter Service Mode.

□ How to enter the Service Menu

1. Press and hold the **MENU** button on Side Controls.
2. Keep pressing the **MENU** button and press the **NUMERIC "1"** button on the remote control, and the service mode menu will be displayed.

Side Controls

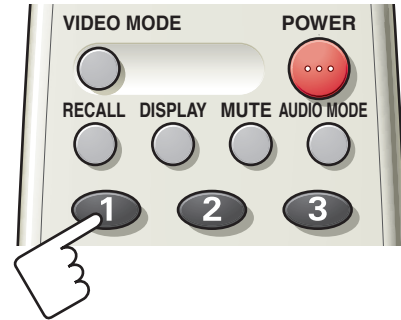
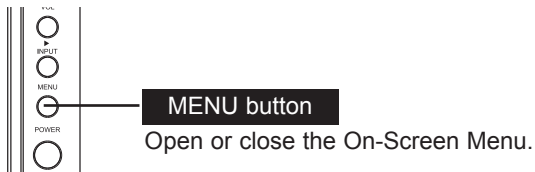

[Service Mode Menu]

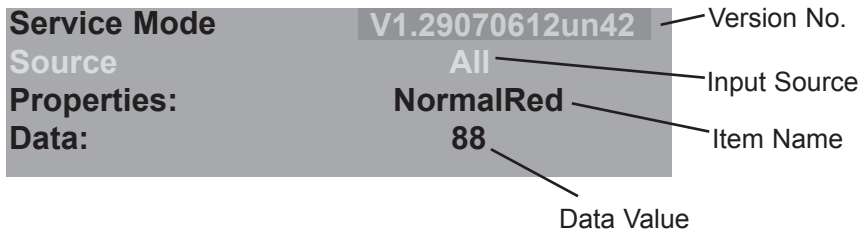

□ How to select the service item and adjust data:

To adjust data:

- 1) Select "DATA" line by pressing ▼ or ▲ button.

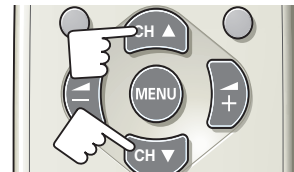
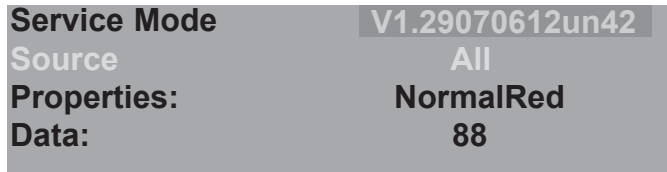

- 2) Press + or - button to adjust data.

□ To exit service mode

1. Press MENU button on the Side Controls or remote control.
2. Turn the TV off by pressing the **POWER ON/OFF** button on the Side Controls or remote control.

Note: The all adjusted data in service mode will be memorized into EEPROM automatically.

On-screen Service Menu System

□ Service Adjustment Data Table

Source	Item Name	Initial Data	IC	Description
1.ALL (General Data) (Basic data)	Normalred	88	FLI8531	White Tone offset
	Normalgreen	99	FLI8531	(Normal)
	Normalblue	99	FLI8531	
	Warmred	88	FLI8531	White Tone offset
	Warmgreen	78	FLI8531	(Warm)
	Warmblue	70	FLI8531	
	Coolred	72	FLI8531	White Tone offset
	Coolgreen	90	FLI8531	(Cool)
	Coolblue	120	FLI8531	
	Red	85	FLI8531	White Balance basic value(AV)
	Green	85	FLI8531	
	Blue	85	FLI8531	
	Brightness	14	FLI8531	User brightness value
	Contrast	58	FLI8531	User contrast value
	Saturation	60	FLI8531	User saturation value
	Hue	-50	FLI8531	User hue value
	Sharpness	7	FLI8531	User sharpness value
	Picmodedynamicbri	50	FLI8531	Brightness basic value (Dynamic)
	Picmodedynamiccon	100	FLI8531	Contrast basic value (Dynamic)
	Picmodedynamicsat	55	FLI8531	Saturation basic value (Dynamic)
	Picmodesoftbri	50	FLI8531	Brightness basic value (Soft)
	Picmodesoftcon	20	FLI8531	Contrast basic value (Soft)
	Picmodesoftsat	50	FLI8531	Saturation basic value (Soft)
	Picmodepersonalbri	50	FLI8531	Brightness basic value (Personal)
	Picmodepersonalcon	70	FLI8531	Contrast basic value (Personal)
	Picmodepersonalsat	50	FLI8531	Saturation basic value (Personal)
	Picmodenormalbri	50	FLI8531	Brightness basic value (Normal)
	Picmodenormalcon	70	FLI8531	Contrast basic value (Normal)
	Picmodenormalsat	50	FLI8531	Saturation basic value (Normal)
	AGC EN	AGC DISABLE	FLI8531	AGC Set : Enable or Disable
	ADC Calibration		FLI8531	ADC adjust entrance
Ver fac		NV	Record data in the factory	
White	RED GREEN BLUE	FLI8531	White Balance adjust interface	
2.TVPALN	Brightnessoffset	23	FLI8531	Brightness offset (RF PALN)
	Contrastoffset	-19	FLI8531	Contrast offset (RF PALN)
	Saturationoffset	0	FLI8531	Saturation offset (RF PALN)
	Hueoffset	0	FLI8531	Hue offset (RF PALN)
	Sharpnessoffset	0	FLI8531	Sharpness offset (RF PALN)
	Redoffset	7	FLI8531	WR offset (RF PALN)
	Greenoffset	-2	FLI8531	WG offset (RF PALN)
	Blueoffset	5	FLI8531	WB offset (RF PALN)
3.TVNTSC	Brightnessoffset	23	FLI8531	Brightness offset (RF NTSC)
	Contrastoffset	-41	FLI8531	Contrast offset (RF NTSC)
	Saturationoffset	0	FLI8531	Saturation offset (RF NTSC)
	Hueoffset	0	FLI8531	Hue offset (RF NTSC)
	Sharpnessoffset	0	FLI8531	Sharpness offset (RF NTSC)
	Redoffset	6	FLI8531	WR offset (RF NTSC)
	Greenoffset	-4	FLI8531	WG offset (RF NTSC)
Blueoffset	6	FLI8531	WB offset (RF NTSC)	
4.TVPLAM	Brightnessoffset	22	FLI8531	Brightness offset (RF PALM)
	Contrastoffset	-4	FLI8531	Contrast offset (RF PALM)
	Saturationoffset	0	FLI8531	Saturation offset (RF PALM)
	Hueoffset	0	FLI8531	Hue offset (RF PALM)
	Sharpnessoffset	0	FLI8531	Sharpness offset (RF PALM)
	Redoffset	0	FLI8531	WR offset (RF PALM)
	Greenoffset	0	FLI8531	WG offset (RF PALM)
Blueoffset	0	FLI8531	WB offset (RF PALM)	

On-screen Service Menu System

Source	Item Name	Initial Data	IC	Description
5.CVBS1PALN/ALL	Normalred	Same as Gerenal data(1.ALL)	FLI8531	Same as Gerenal data(1.ALL)-->
(Gerenal Data)	Normalgreen		FLI8531	
	Normalblue		FLI8531	
	Warmred		FLI8531	
	Warmgreen		FLI8531	
	Warmblue		FLI8531	
	Coolred		FLI8531	
	Coolgreen		FLI8531	
	Coolblue		FLI8531	
	Red		FLI8531	
	Green		FLI8531	
	Blue		FLI8531	
	Brightness		FLI8531	
	Contrast		FLI8531	
	Saturation		FLI8531	
	Hue		FLI8531	
	Sharpness		FLI8531	
	Picmodedynamicbri		FLI8531	
	Picmodedynamiccon		FLI8531	
	Picmodedynamicsat		FLI8531	
	Picmodesoftbri		FLI8531	
	Picmodesoftcon		FLI8531	
	Picmodesoftsat		FLI8531	
	Picmodepersonalbri		FLI8531	
	Picmodepersonalcon		FLI8531	
	Picmodepersonalsat		FLI8531	
	Picmodenormalbri		FLI8531	
	Picmodenormalcon		FLI8531	
	Picmodenormalsat		FLI8531	
	AGC EN	AGC DISABLE	FLI8531	
	ADC Calibration		FLI8531	
	Ver fac		NV	
	White	RED GREEN BLUE	FLI8531	Same as Gerenal data(1.ALL) <--
6.CVBS1NTSC	Brightnessoffset	0	FLI8531	Brightness offset (AV1 NTSC)
	Contrastoffset	-13	FLI8531	Contrast offset (AV1 NTSC)
	Saturationoffset	0	FLI8531	Saturation offset (AV1 NTSC)
	Hueoffset	0	FLI8531	Hue offset (AV1 NTSC)
	Sharpnessoffset	0	FLI8531	Sharpness offset (AV1 NTSC)
	Redoffset	0	FLI8531	WR offset (AV1 NTSC)
	Greenoffset	0	FLI8531	WG offset (AV1 NTSC)
	Blueoffset	0	FLI8531	WB offset (AV1 NTSC)
7.CVBS1PALM	Brightnessoffset	1	FLI8531	Brightness offset (AV1 PALM)
	Contrastoffset	9	FLI8531	Contrast offset (AV1 PALM)
	Saturationoffset	0	FLI8531	Saturation offset (AV1 PALM)
	Hueoffset	0	FLI8531	Hue offset (AV1 PALM)
	Sharpnessoffset	0	FLI8531	Sharpness offset (AV1 PALM)
	Redoffset	0	FLI8531	WR offset (AV1 PALM)
	Greenoffset	0	FLI8531	WG offset (AV1 PALM)
	Blueoffset	0	FLI8531	WB offset (AV1 PALM)
8.CVBS2PAL/ ALLPORT	Normalred	Same as Gerenal data(1.ALL)-->	FLI8531	Same as Gerenal data(1.ALL)-->
	Normalgreen		FLI8531	
	Normalblue		FLI8531	
	Warmred		FLI8531	
	Warmgreen		FLI8531	
	Warmblue		FLI8531	
	Coolred		FLI8531	

On-screen Service Menu System

Source	Item Name	Initial Data	IC	Description
	Coolgreen		FLI8531	
	Coolblue		FLI8531	
	Red		FLI8531	
	Green		FLI8531	
	Blue		FLI8531	
	Brightness		FLI8531	
	Contrast		FLI8531	
	Saturation		FLI8531	
	Hue		FLI8531	
	Sharpness		FLI8531	
	Picmodedynamicbri		FLI8531	
	Picmodedynamiccon		FLI8531	
	Picmodedynamicsat		FLI8531	
	Picmodesoftbri		FLI8531	
	Picmodesoftcon		FLI8531	
	Picmodesoftsat		FLI8531	
	Picmodepersonalbri		FLI8531	
	Picmodepersonalcon		FLI8531	
	Picmodepersonalsat		FLI8531	
	Picmodenormalbri		FLI8531	
	Picmodenormalcon		FLI8531	
	Picmodenormalsat		FLI8531	
	AGC EN		FLI8531	
	ADC Calibration		FLI8531	
	Ver fac		NV	
	White	Same as Gerenal data(1.ALL)<--	FLI8531	Same as Gerenal data(1.ALL) <--
9.CVBS2NTSC	Brightnessoffset	0	FLI8531	Brightness offset (AV2 NTSC)
	Contrastoffset	-13	FLI8531	Contrast offset (AV2 NTSC)
	Saturationoffset	0	FLI8531	Saturation offset (AV2 NTSC)
	Hueoffset	0	FLI8531	Hue offset (AV2 NTSC)
	Sharpnessoffset	0	FLI8531	Sharpness offset (AV2 NTSC)
	Redoffset	0	FLI8531	WR offset (AV2 NTSC)
	Greenoffset	0	FLI8531	WG offset (AV2 NTSC)
	Blueoffset	0	FLI8531	WB offset (AV2 NTSC)
10.CVBS2PALM	Brightnessoffset	1	FLI8531	Brightness offset (AV2 PALM)
	Contrastoffset	9	FLI8531	Contrast offset (AV2 PALM)
	Saturationoffset	0	FLI8531	Saturation offset (AV2 PALM)
	Hueoffset	0	FLI8531	Hue offset (AV2 PALM)
	Sharpnessoffset	0	FLI8531	Sharpness offset (AV2 PALM)
	Redoffset	0	FLI8531	WR offset (AV2 PALM)
	Greenoffset	0	FLI8531	WG offset (AV2 PALM)
	Blueoffset	0	FLI8531	WB offset (AV2 PALM)
11.SVIDEOPALN	Brightnessoffset	-5	FLI8531	Brightness offset (Svideo PALN)
	Contrastoffset	0	FLI8531	Contrast offset (Svideo PALN)
	Saturationoffset	0	FLI8531	Saturation offset (Svideo PALN)
	Hueoffset	0	FLI8531	Hue offset (Svideo PALN)
	Sharpnessoffset	0	FLI8531	Sharpness offset (Svideo PALN)
	Redoffset	0	FLI8531	WR offset (Svideo PALN)
	Greenoffset	0	FLI8531	WG offset (Svideo PALN)
	Blueoffset	0	FLI8531	WB offset (Svideo PALN)
12.SVIDEONTSC	Brightnessoffset	0	FLI8531	Brightness offset (Svideo NTSC)
	Contrastoffset	-20	FLI8531	Contrast offset (Svideo NTSC)
	Saturationoffset	0	FLI8531	Saturation offset (Svideo NTSC)
	Hueoffset	0	FLI8531	Hue offset (Svideo NTSC)
	Sharpnessoffset	0	FLI8531	Sharpness offset (Svideo NTSC)
	Redoffset	0	FLI8531	WR offset (Svideo NTSC)
	Greenoffset	0	FLI8531	WG offset (Svideo NTSC)
	Blueoffset	0	FLI8531	WB offset (Svideo NTSC)

On-screen Service Menu System

Source	Item Name	Initial Data	IC	Description
13.SVIDEOPALM	Brightnessoffset	0	FLI8531	Brightness offset (Svideo PALM)
	Contrastoffset	15	FLI8531	Contrast offset (Svideo PALM)
	Saturationoffset	0	FLI8531	Saturation offset (Svideo PALM)
	Hueoffset	0	FLI8531	Hue offset (Svideo PALM)
	Sharpnessoffset	0	FLI8531	Sharpness offset (Svideo PALM)
	Redoffset	0	FLI8531	WR offset (Svideo PALM)
	Greenoffset	0	FLI8531	WG offset (Svideo PALM)
	Blueoffset	0	FLI8531	WB offset (Svideo PALM)
14.COMP480I PORT (Component)	Brightnessoffset	18	FLI8531	Brightness offset (Component 480i)
	Contrastoffset	25	FLI8531	Contrast offset (Component 480i)
	Saturationoffset	40	FLI8531	Saturation offset (Component 480i)
	Hueoffset	0	FLI8531	Hue offset (Component 480i)
	Sharpnessoffset	3	FLI8531	Sharpness offset (Component 480i)
	Redoffset	0	FLI8531	WR offset (Component 480i)
	Greenoffset	0	FLI8531	WG offset (Component 480i)
	Blueoffset	0	FLI8531	WB offset (Component 480i)
15.COMP576I PORT (Component)	Brightnessoffset	18	FLI8531	Brightness offset (Component 575i)
	Contrastoffset	25	FLI8531	Contrast offset (Component 575i)
	Saturationoffset	40	FLI8531	Saturation offset (Component 575i)
	Hueoffset	0	FLI8531	Hue offset (Component 575i)
	Sharpnessoffset	3	FLI8531	Sharpness offset (Component 575i)
	Redoffset	0	FLI8531	WR offset (Component 575i)
	Greenoffset	0	FLI8531	WG offset (Component 575i)
	Blueoffset	0	FLI8531	WB offset (Component 575i)
16.COMP480P PORT (Component)	Brightnessoffset	18	FLI8531	Brightness offset (Component 480p)
	Contrastoffset	25	FLI8531	Contrast offset (Component 480p)
	Saturationoffset	40	FLI8531	Saturation offset (Component 480p)
	Hueoffset	0	FLI8531	Hue offset (Component 480p)
	Sharpnessoffset	3	FLI8531	Sharpness offset (Component 480p)
	Redoffset	0	FLI8531	WR offset (Component 480p)
	Greenoffset	0	FLI8531	WG offset (Component 480p)
	Blueoffset	0	FLI8531	WB offset (Component 480p)
17.COMP576P PORT (Component)	Brightnessoffset	18	FLI8531	Brightness offset (Component 575p)
	Contrastoffset	25	FLI8531	Contrast offset (Component 575p)
	Saturationoffset	40	FLI8531	Saturation offset (Component 575p)
	Hueoffset	0	FLI8531	Hue offset (Component 575p)
	Sharpnessoffset	3	FLI8531	Sharpness offset (Component 575p)
	Redoffset	0	FLI8531	WR offset (Component 575p)
	Greenoffset	0	FLI8531	WG offset (Component 575p)
	Blueoffset	0	FLI8531	WB offset (Component 575p)
18.COMP720P 50 PORT (Component) (720p 50Hz)	Brightnessoffset	18	FLI8531	Brightness offset(Component 720p 50Hz)
	Contrastoffset	25	FLI8531	Contrast offset(Component 720p 50Hz)
	Saturationoffset	40	FLI8531	Saturation offset(Component 720p 50Hz)
	Hueoffset	0	FLI8531	Hue offset(Component 720p 50Hz)
	Sharpnessoffset	3	FLI8531	Sharpness offset(Component 720p 50Hz)
	Redoffset	0	FLI8531	WR offset(Component 720p 50Hz)
	Greenoffset	0	FLI8531	WG offset(Component 720p 50Hz)
	Blueoffset	0	FLI8531	WB offset(Component 720p 50Hz)
19.COMP720P 60 PORT (Component) (720p 60Hz)	Brightnessoffset	18	FLI8531	Brightness offset(Component 720p 60Hz)
	Contrastoffset	25	FLI8531	Contrast offset(Component 720p 60Hz)
	Saturationoffset	40	FLI8531	Saturation offset(Component 720p 60Hz)
	Hueoffset	0	FLI8531	Hue offset(Component 720p 60Hz)
	Sharpnessoffset	3	FLI8531	Sharpness offset(Component 720p 60Hz)
	Redoffset	0	FLI8531	WR offset(Component 720p 60Hz)
	Greenoffset	0	FLI8531	WG offset(Component 720p 60Hz)
	Blueoffset	0	FLI8531	WB offset(Component 720p 60Hz)

On-screen Service Menu System

Source	Item Name	Initial Data	IC	Description
20.COMP1080i 50 PORT (Component) (1080i 50Hz)	Brightnessoffset	18	FLI8531	Brightness offset(Component 1080i/50Hz)
	Contrastoffset	25	FLI8531	Contrast offset(Component 1080i/50Hz)
	Saturationoffset	40	FLI8531	Saturation offset(Component 1080i/50Hz)
	Hueoffset	0	FLI8531	Hue offset(Component 1080i/50Hz)
	Sharpnessoffset	3	FLI8531	Sharpness offset(Component 1080i/50Hz)
	Redoffset	0	FLI8531	WR offset(Component 1080i/50Hz)
	Greenoffset	0	FLI8531	WG offset(Component 1080i/50Hz)
21.COMP1080i 60 PORT (Component) (1080i 60Hz)	Blueoffset	0	FLI8531	WB offset(Component 1080i/50Hz)
	Brightnessoffset	18	FLI8531	Brightness offset(Component 1080i/60Hz)
	Contrastoffset	25	FLI8531	Contrast offset(Component 1080i/60Hz)
	Saturationoffset	40	FLI8531	Saturation offset(Component 1080i/60Hz)
	Hueoffset	0	FLI8531	Hue offset(Component 1080i/60Hz)
	Sharpnessoffset	3	FLI8531	Sharpness offset(Component 1080i/60Hz)
	Redoffset	0	FLI8531	WR offset(Component 1080i/60Hz)
22.COMP1080P 25 PORT (Component) (1080p 25Hz)	Greenoffset	0	FLI8531	WG offset(Component 1080i/60Hz)
	Blueoffset	0	FLI8531	WB offset(Component 1080i/60Hz)
	Brightnessoffset	18	FLI8531	Brightness offset(Component 1080p/25Hz)
	Contrastoffset	25	FLI8531	Contrast offset(Component 1080p/25Hz)
	Saturationoffset	40	FLI8531	Saturation offset(Component 1080p/25Hz)
	Hueoffset	0	FLI8531	Hue offset(Component 1080p/25Hz)
	Sharpnessoffset	3	FLI8531	Sharpness offset(Component 1080p/25Hz)
23.COMP1080P 30 PORT (Component) (1080p 30Hz)	Redoffset	0	FLI8531	WR offset(Component 1080p/25Hz)
	Greenoffset	0	FLI8531	WG offset(Component 1080p/25Hz)
	Blueoffset	0	FLI8531	WB offset(Component 1080p/25Hz)
	Brightnessoffset	18	FLI8531	Brightness offset(Component 1080p/30Hz)
	Contrastoffset	25	FLI8531	Contrast offset(Component 1080p/30Hz)
	Saturationoffset	40	FLI8531	Saturation offset(Component 1080p/30Hz)
	Hueoffset	0	FLI8531	Hue offset(Component 1080p/30Hz)
24.COMP1080P 50 PORT (Component) (1080p 50Hz)	Sharpnessoffset	3	FLI8531	Sharpness offset(Component 1080p/30Hz)
	Redoffset	0	FLI8531	WR offset(Component 1080p/30Hz)
	Greenoffset	0	FLI8531	WG offset(Component 1080p/30Hz)
	Blueoffset	0	FLI8531	WB offset(Component 1080p/30Hz)
	Brightnessoffset	18	FLI8531	Brightness offset(Component 1080p/50Hz)
	Contrastoffset	25	FLI8531	Contrast offset(Component 1080p/50Hz)
	Saturationoffset	40	FLI8531	Saturation offset(Component 1080p/50Hz)
25.COMP1080P 60 PORT (Component) (1080p 60Hz)	Hueoffset	0	FLI8531	Hue offset(Component 1080p/50Hz)
	Sharpnessoffset	3	FLI8531	Sharpness offset(Component 1080p/50Hz)
	Redoffset	0	FLI8531	WR offset(Component 1080p/50Hz)
	Greenoffset	0	FLI8531	WG offset(Component 1080p/50Hz)
	Blueoffset	0	FLI8531	WB offset(Component 1080p/50Hz)
	Brightnessoffset	18	FLI8531	Brightness offset(Component 1080p/60Hz)
	Contrastoffset	25	FLI8531	Contrast offset(Component 1080p/60Hz)
26.VGA	Saturationoffset	40	FLI8531	Saturation offset(Component 1080p/60Hz)
	Hueoffset	0	FLI8531	Hue offset(Component 1080p/60Hz)
	Sharpnessoffset	3	FLI8531	Sharpness offset(Component 1080p/60Hz)
	Redoffset	0	FLI8531	WR offset(Component 1080p/60Hz)
	Greenoffset	0	FLI8531	WG offset(Component 1080p/60Hz)
	Blueoffset	0	FLI8531	WB offset(Component 1080p/60Hz)
	Brightnessoffset	22	FLI8531	Brightness offset(VGA)
27.HDMI	Contrastoffset	30	FLI8531	Contrast offset(VGA)
	Saturationoffset	0	FLI8531	Saturation offset(VGA)
	Hueoffset	0	FLI8531	Hue offset(VGA)
	Sharpnessoffset	0	FLI8531	Sharpness offset(VGA)
	Redoffset	0	FLI8531	WR offset(VGA)
	Greenoffset	0	FLI8531	WG offset(VGA)
	Blueoffset	0	FLI8531	WB offset(VGA)
27.HDMI	Brightnessoffset	20	FLI8531	Brightness offset (HDMI)
	Contrastoffset	-42	FLI8531	Contrast offset(HDMI)
	Saturationoffset	0	FLI8531	Saturation offset(HDMI)
	Hueoffset	0	FLI8531	Hue offset(HDMI)
	Sharpnessoffset	0	FLI8531	Sharpness offset(HDMI)
	Redoffset	0	FLI8531	WR offset(HDMI)
	Greenoffset	0	FLI8531	WG offset(HDMI)
Blueoffset	0	FLI8531	WB offset(HDMI)	

Service Adjustments

CAUTION !

Do not attempt to adjust service adjustments not listed below otherwise it may cause loss of performance and for correct operation.

□ Setting the Initial data

This adjustment is controlled by the CPU (IC7200) through the IIC Bus Data Line in the chassis, and those adjustment data are memorized the memory IC (IC8002). Therefore, Main board or the memory IC (IC8002) is replaced, these data will be disappeared. Readjust should be made. Initial data is provided in the CPU ROM, when the memory IC (IC8002) is replaced with new one. CPU ROM data is loaded into the memory. Initial data is provided to operating the monitor basically. For operating the monitor quality performance, further adjustment is required following chassis electrical adjustment.

1. Receive good quality signal.
2. Enter the Service Mode.
3. Confirm data value to be the same as the **Service Adjustment Data Table**. If it is different, change to correct data
4. Exit the Service Mode.

□ White balance Adjustment

Pattern

White Pattern 100% (in AV mode).

Condition

Picture Mode: STANDARD

Color Temperature: NORMAL

Pre-heating Time: More than 10 minutes

Adjustment

1. Enter the Service Mode.
2. Select "**Source ALL**" by pressing \uparrow or \leftarrow button, and select "**Properties White**" by pressing \uparrow or \leftarrow button.
3. Set R,G,B value to "FF" by pressing NUMERIC buttons.
To adjust Red : Press **1** (data value up) and **4** (data value down).
To adjust Green : Press **2** (data value up) and **5** (data value down).
To adjust Blue : Press **3** (data value up) and **6** (data value down).

Service Mode	V1.29070612un42	
Source	All	
Properties:	White	
Red 0	Green 0	Blue 0

4. Decide one item in three items to a fixed value (For example, let **R** be fixed value), select item of other 2 colors (Example, **G** or **B**), and adjust to produce a normal black and white picture in highlight areas.
(**Note:** At this time, Adjust the other 2 colors data less than fixed data.)
5. Exit the Service Mode.

After adjustment, confirm white balance again by normal picture.

Mechanical Disassembly

[Disassembly Diagram]

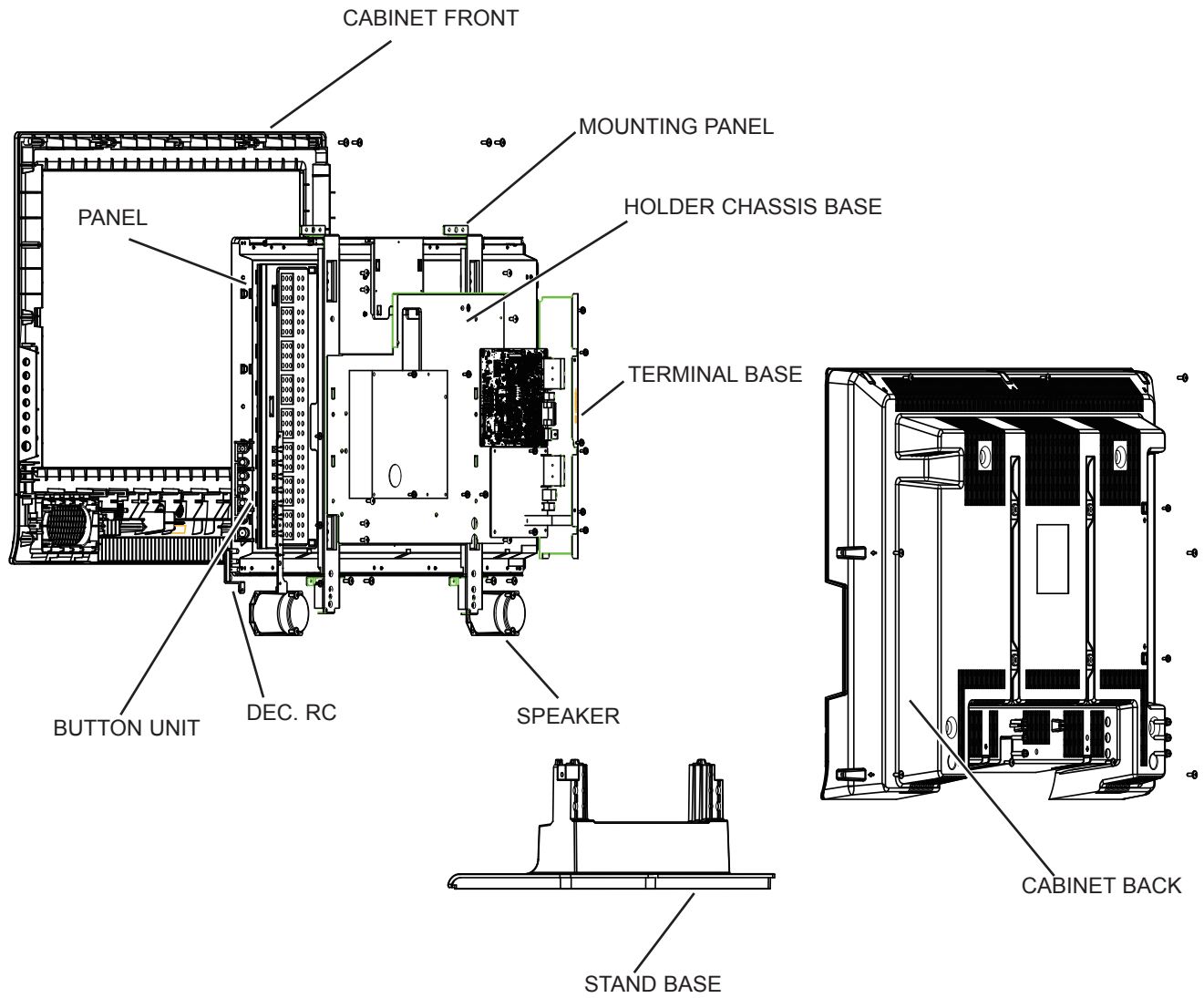

Mechanical Disassembly

1. Stand Removal

1. Remove 6 screws and remove the Stand.

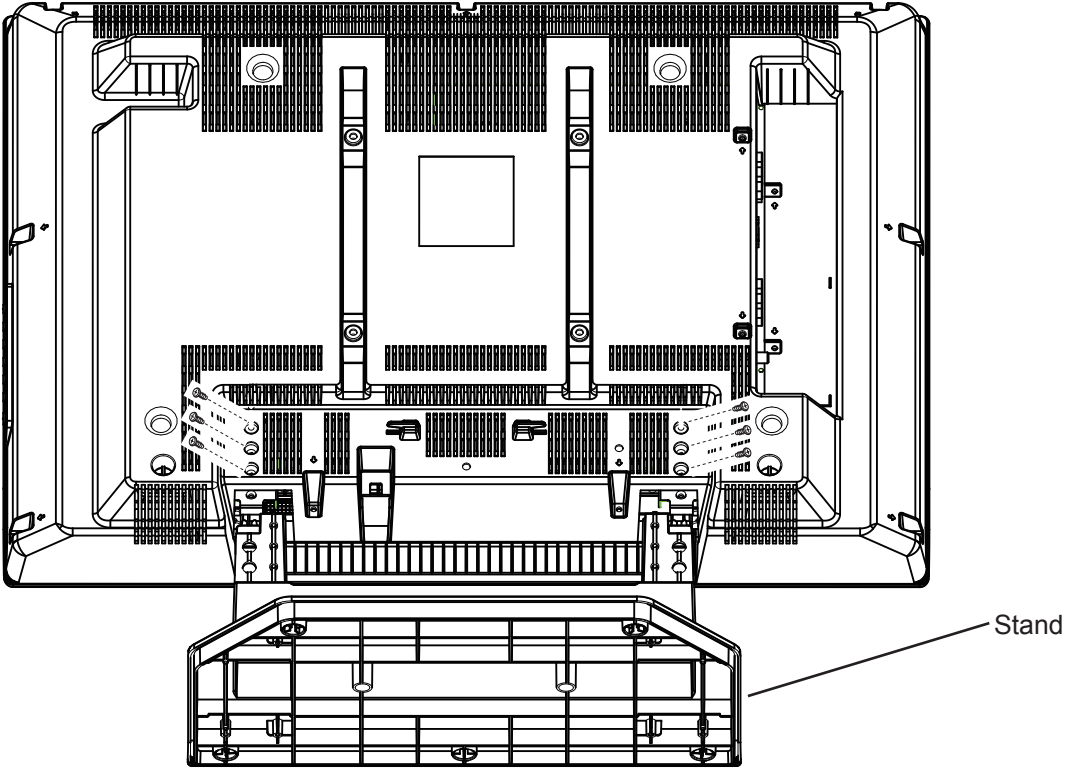

Mechanical Disassembly

2. Cabinet Back Removal

1. Remove 13 screws and take the Cabinet Back off.

Note: Cabinet Back can be removed even if it does not remove a stand.

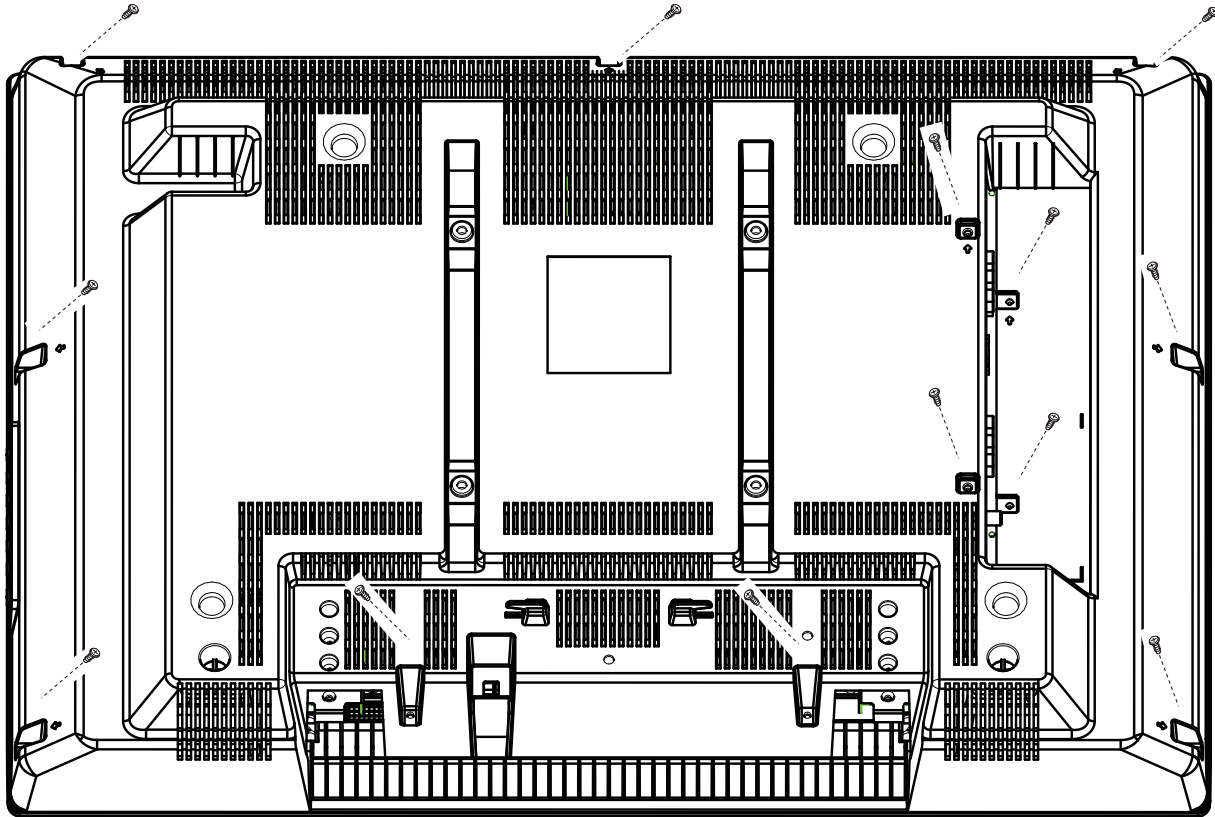

Mechanical Disassembly

3. Circuit Board Removal

1. Remove 6 screws and take **ASSY, PWB, POWER** off.
2. Remove 4 screws on the circuit board and then take **ASSY, PWB, MAIN** off .
3. Remove 4 screws on the circuit board and then take **ASSY, PWB, SUB** off .

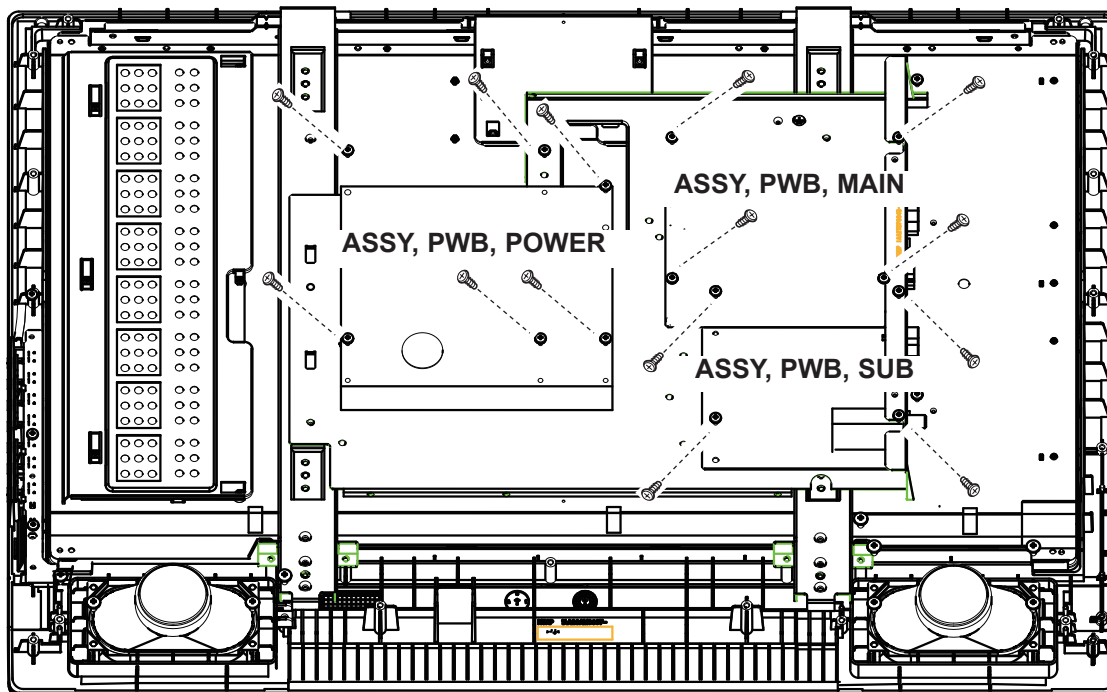

4. Remove 3 screws and take **ASSY, PWB, KEY** off .
5. Remove 2 screws and take **TERMINAL BOARD** off .

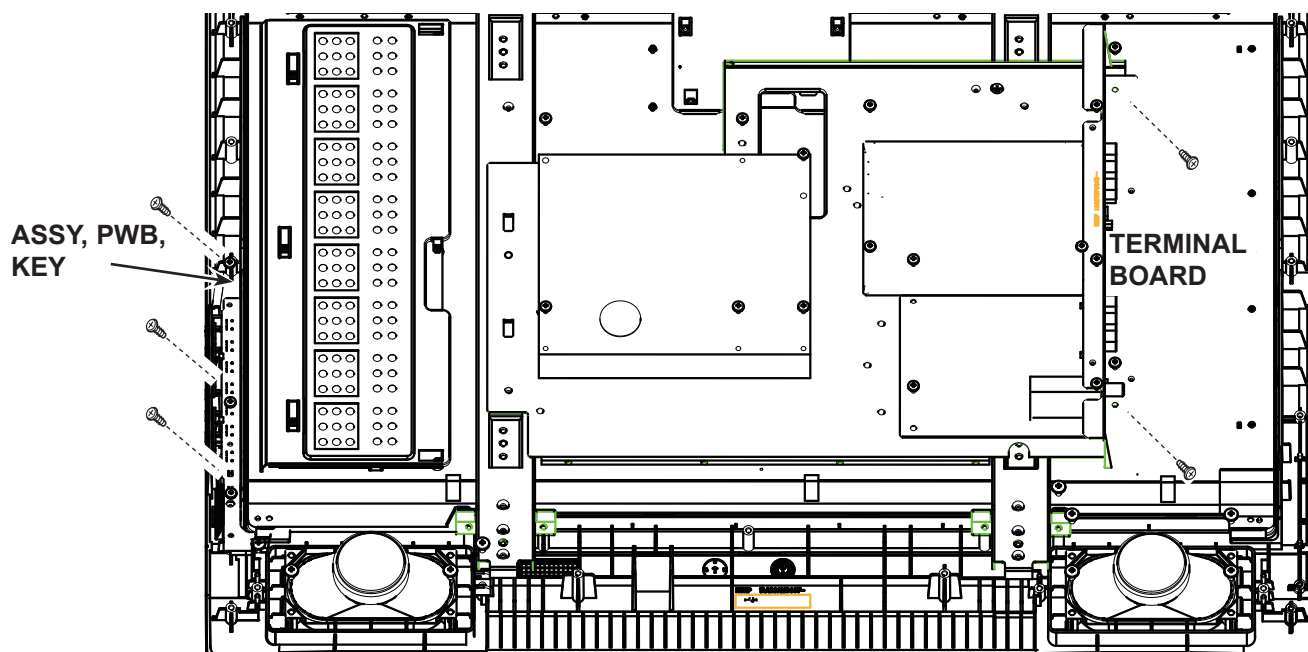

Mechanical Disassembly

4. LCD Panel Removal

1. Remove 16 screws and take HOLDER off.

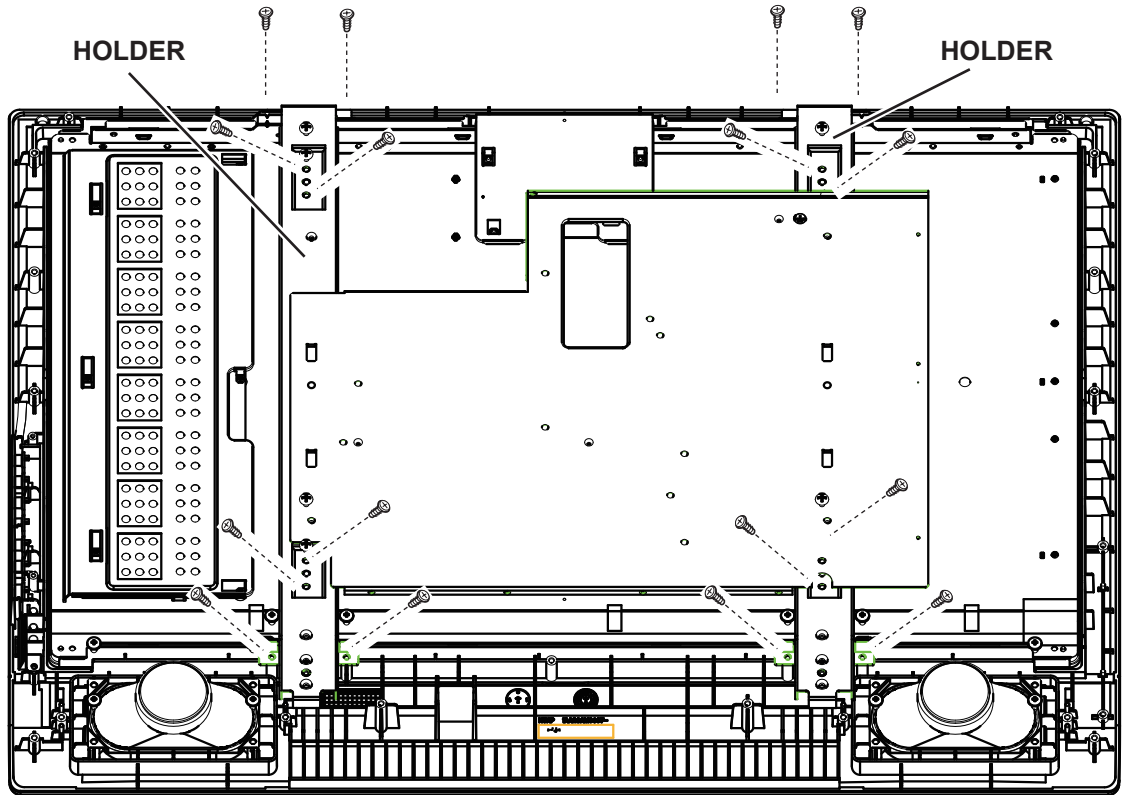

2. Remove 3 screws and take PANEL HOLDER off.

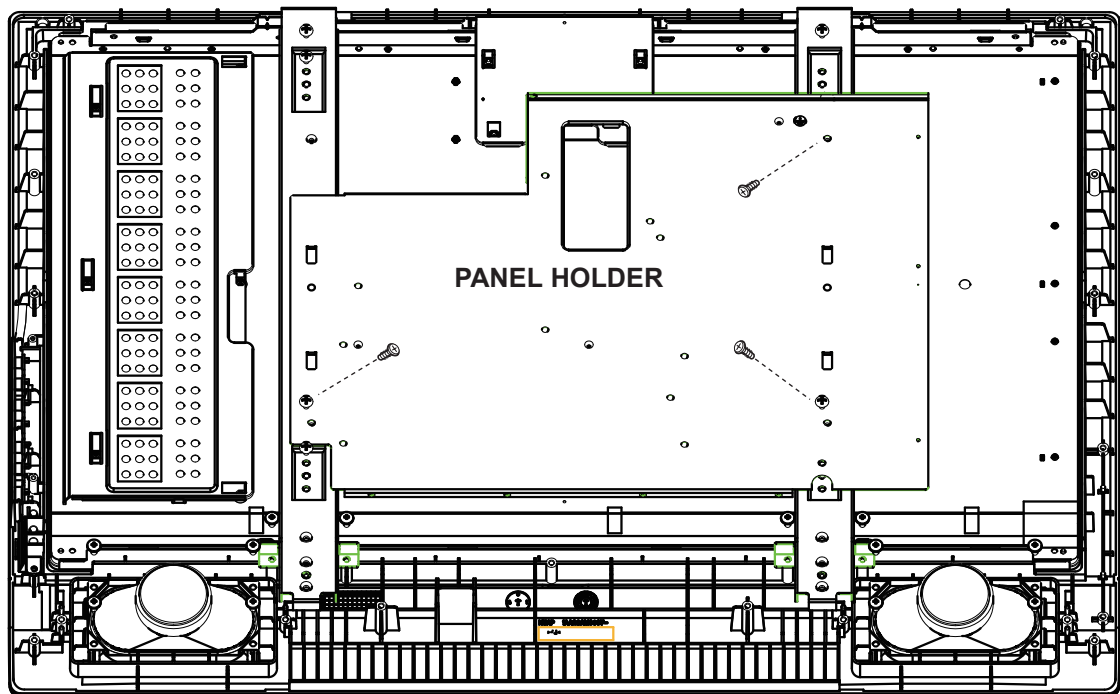

Mechanical Disassembly

5. SPEAKER Removal

1. Remove 8 screws and take SPEAKER off.

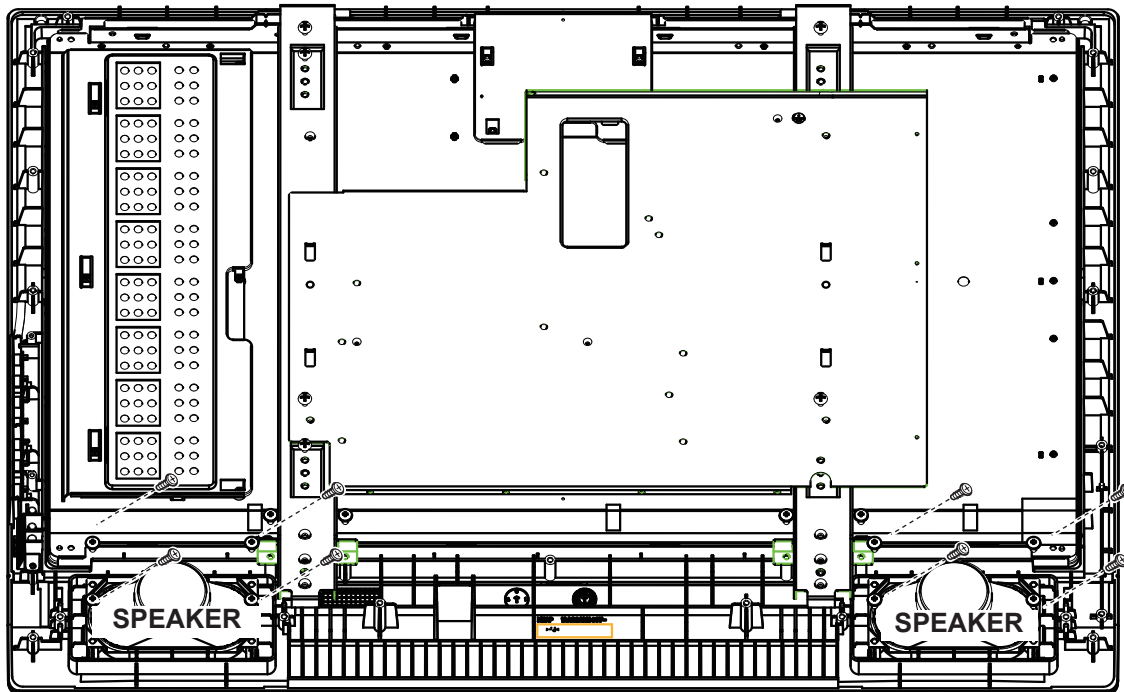

Cabinet Parts List

Note: Parts order must contain Service Ref. No., Part No., and descriptions.

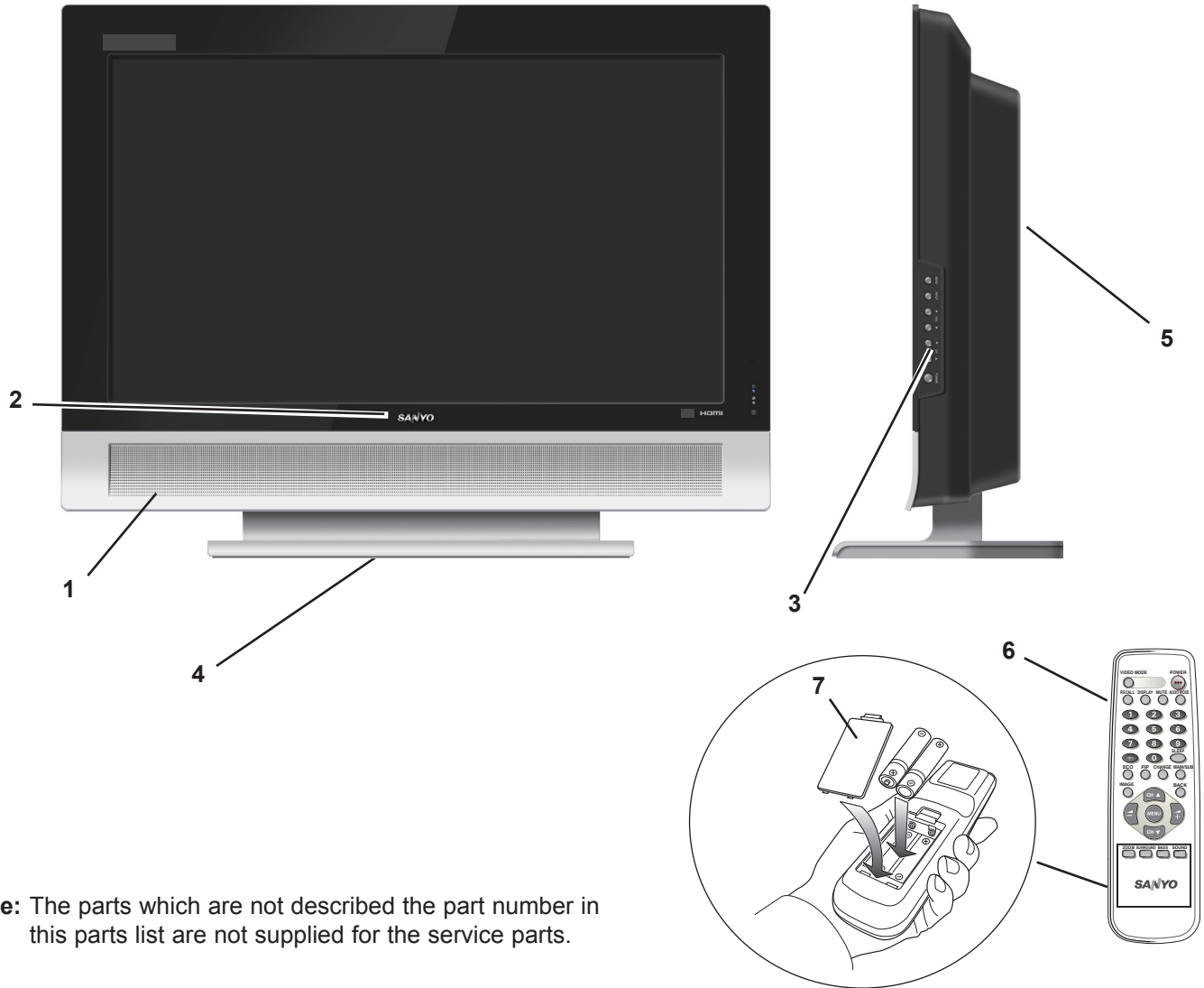

Note: The parts which are not described the part number in this parts list are not supplied for the service parts.

Key No.	Part No.	Description	Key No.	Part No.	Description
1	1AA2CAM0607-B	CABINET FRONT-N5AV			
2	1LG2BAA0008--	BADGE,SANYO*43.5X10L43.5			
3	1AA2BUM0562--	BUTTON UNIT-N5BP			
4	1AA2SDM0180--	STAND BASE-N5BP			
5	1AA2CBM0439--	CABINET BACK-N5AP			
6	1AV0U10B44900	ASSY,REMOCON JXMTL			
7	1AA2RCM0306--	RC-BATTERY LID-JXMTL			
	1LG6P1P0235--	INSTRUCTION MANUAL-N5AV			



Chassis Electrical Parts List

Product safety should be considered when a component replacement is made in any area of a receiver. Components indicated by a Δ mark in this parts list and the circuit diagram show components whose value have special significance to product safety. It is particularly recommended that only parts specified on the following parts list be used for components replacement pointed out by the mark.

Note: Parts order must contain Service Ref. No., Part No., and descriptions.

Ref. No.	Part No.	Description	Safety	Ref. No.	Part No.	Description	Safety
A013N5AV	013N5AV	ELECTRICAL PARTS DIRECTORY		C030	CK1C475ZGBFNG	CERAMIC 4.7U Z 16V	
EL901	1AV4T40B86400	LCD(T315XW02 VC03)	Δ	C030	CK1C475ZGNFNG	CERAMIC 4.7U Z 16V	
SP901	1LB4A10B05700	SPEAKER,8		C1034	CCXAV1H100ABG	CERAMIC 10PJ 50.0V	
SP901	1LB4A10B08700	SPEAKER,8		C1034	CCXLB1H100ZBG	CERAMIC 10P J 50V	
SP902	1LB4A10B05700	SPEAKER,8		C1038	CCXAV1H100ABG	CERAMIC 10PJ 50.0V	
SP902	1LB4A10B08700	SPEAKER,8		C1038	CCXLB1H100ZBG	CERAMIC 10P J 50V	
WKEY-800	1AA97CM07980X	STANDARD WIRE		C1512	CK1A105MLZBNG	CERAMIC 1U M 10V	
WPOW-404	1LB4W30B11500	CORD,ID-CONNECTOR		C1513	CK1A105MLZBNG	CERAMIC 1U M 10V	
WSP9L	1LB9W03CM001C	NONSTANDARD WIRE ASSY		C1514	CK1A105MLZBNG	CERAMIC 1U M 10V	
WSP9R	1LB9W02CM001A	NONSTANDARD WIRE ASSY		C1515	RGFR000ZTCANL	MT-GLAZE 0.000 ZA 1/10W	
W101-101	1AA98CM01220X	STANDARD WIRE		C1516	RGFR000ZTCANL	MT-GLAZE 0.000 ZA 1/10W	
W2PCB-CN	1LB9W0ECM004-	NONSTANDARD WIRE ASSY		C1522	CKXAV1C104EAG	CERAMIC 0.1U K 16V	
W32V-405	1AA92BG01300X	STANDARD WIRE ASSY-JPN		C1522	CKXLB1C104YAG	CERAMIC 0.1U K 16V	
W7205	1LB4W30B12100	CORD 30PIN (LVDS)		C1522	CK1C104KGQBNG	CERAMIC 0.1U K 16V	
W901	1LB4W10B01900	CORD,POWER	Δ	C1530	CE1C471MKNANG	ELECT 470U M 16V	
A1000	1LG0B10Y01800	ASSY,PWB,MAIN N5AV		C1530	CE1C471M1WANG	ELECT 470U M 16V	
C001	CE1E101MKNANG	ELECT 100U M 25V		C1535	CE1C101M1WANG	ELECT 100U M 16V	
C001	CE1E101M1WANG	ELECT 100U M 25V		C1536	CKXAV1C104EAG	CERAMIC 0.1U K 16V	
C002	CK1C475ZGBFNG	CERAMIC 4.7U Z 16V		C1536	CKXLB1C104YAG	CERAMIC 0.1U K 16V	
C002	CK1C475ZGNFNG	CERAMIC 4.7U Z 16V		C1536	CK1C104KGQBNG	CERAMIC 0.1U K 16V	
C004	CKXAV1A224EAG	CERAMIC 0.22U K 10V		C2209	CKXAV1C104EAG	CERAMIC 0.1U K 16V	
C004	CKXLB1A224YAG	CERAMIC 0.22U K 10V		C2209	CKXLB1C104YAG	CERAMIC 0.1U K 16V	
C004	CK1A224KGQBNG	CERAMIC 0.22U K 10V		C2209	CK1C104KGQBNG	CERAMIC 0.1U K 16V	
C006	CK1C475ZGBFNG	CERAMIC 4.7U Z 16V		C2210	CE1C101MKNANG	ELECT 100U M 16V	
C006	CK1C475ZGNFNG	CERAMIC 4.7U Z 16V		C2210	CE1C101M1WANG	ELECT 100U M 16V	
C007	CK1C475ZGBFNG	CERAMIC 4.7U Z 16V		C2211	CE1C471MKNANG	ELECT 470U M 16V	
C007	CK1C475ZGNFNG	CERAMIC 4.7U Z 16V		C2211	CE1C471M1WANG	ELECT 470U M 16V	
C010	CKXLB1H103YDG	CERAMIC 0.01U Z 50V		C2212	CKXAV1C104EAG	CERAMIC 0.1U K 16V	
C011	CKXAV1A224EAG	CERAMIC 0.22U K 10V		C2212	CKXLB1C104YAG	CERAMIC 0.1U K 16V	
C011	CKXLB1A224YAG	CERAMIC 0.22U K 10V		C2212	CK1C104KGQBNG	CERAMIC 0.1U K 16V	
C011	CK1A224KGQBNG	CERAMIC 0.22U K 10V		C2213	CE1C101M1WANG	ELECT 100U M 16V	
C012	CK1C475ZGBFNG	CERAMIC 4.7U Z 16V		C2214	CKXAV1C104EAG	CERAMIC 0.1U K 16V	
C012	CK1C475ZGNFNG	CERAMIC 4.7U Z 16V		C2214	CKXLB1C104YAG	CERAMIC 0.1U K 16V	
C014	CE1E101MKNANG	ELECT 100U M 25V		C2214	CK1C104KGQBNG	CERAMIC 0.1U K 16V	
C014	CE1E101M1WANG	ELECT 100U M 25V		C2215	CKXAV1C104EAG	CERAMIC 0.1U K 16V	
C015	CK1H104KLZBNG	CERAMIC 0.1U K 50V		C2215	CKXLB1C104YAG	CERAMIC 0.1U K 16V	
C016	CEXLB1C100VAG	ELECT 10U M 16V		C2215	CK1C104KGQBNG	CERAMIC 0.1U K 16V	
C016	CE1C100MKNANG	ELECT 10U M 16V		C2216	CKXAV1C104EAG	CERAMIC 0.1U K 16V	
C016	CE1C100M1WANG	ELECT 10U M 16V		C2216	CKXLB1C104YAG	CERAMIC 0.1U K 16V	
C017	CK1H104KLZBNG	CERAMIC 0.1U K 50V		C2216	CK1C104KGQBNG	CERAMIC 0.1U K 16V	
C017	CK1H104ZGQFNG	CERAMIC 0.1U Z 50V		C2217	CE1C471MKNANG	ELECT 470U M 16V	
C018	CE1C331MKNANG	ELECT 330U M 16V		C2217	CE1C471M1WANG	ELECT 470U M 16V	
C018	CE1C331M1WANG	ELECT 330U M 16V		C2220	CKXAV1C104EAG	CERAMIC 0.1U K 16V	
C019	CKXLB1H103YDG	CERAMIC 0.01U Z 50V		C2220	CKXLB1C104YAG	CERAMIC 0.1U K 16V	
C020	CKXLB1H103YDG	CERAMIC 0.01U Z 50V		C2220	CK1C104KGQBNG	CERAMIC 0.1U K 16V	
C021	CKXLB1H224YAG	CERAMIC 0.22U K 50V		C2221	CE1C101MKNANG	ELECT 100U M 16V	
C022	CKXLB1H103YDG	CERAMIC 0.01U Z 50V		C2221	CE1C101M1WANG	ELECT 100U M 16V	
C023	CKXLB1H103YDG	CERAMIC 0.01U Z 50V		C2300	CKXAV1C104EAG	CERAMIC 0.1U K 16V	
C024	CKXLB1H224YAG	CERAMIC 0.22U K 50V		C2300	CKXLB1C104YAG	CERAMIC 0.1U K 16V	
C026	CE1C331MKNANG	ELECT 330U M 16V		C2300	CK1C104KGQBNG	CERAMIC 0.1U K 16V	
C026	CE1C331M1WANG	ELECT 330U M 16V		C2301	CKXAV1C104EAG	CERAMIC 0.1U K 16V	
C029	CK1C475ZGBFNG	CERAMIC 4.7U Z 16V		C2301	CKXLB1C104YAG	CERAMIC 0.1U K 16V	
C029	CK1C475ZGNFNG	CERAMIC 4.7U Z 16V		C2301	CK1C104KGQBNG	CERAMIC 0.1U K 16V	
				C2302	CE1C470MKNANG	ELECT 47U M 16V	

Ref. No.	Part No.	Description	Safety	Ref. No.	Part No.	Description	Safety
C2302	CE1C470M1WANG	ELECT 47U M 16V		C7227	CK1C104KGQBNG	CERAMIC 0.1U K 16V	
C2305	CE0J220MKNANG	ELECT 22U M 6.3V		C7228	CE0J220MKNANG	ELECT 22U M 6.3V	
C2305	CE0J220M1WANG	ELECT 22U M 6.3V		C7228	CE0J220M1WANG	ELECT 22U M 6.3V	
C7200	CCXAV1H8R0AAG	CERAMIC 8P D 50V		C7229	CKXAV1C104EAG	CERAMIC 0.1U K 16V	
C7200	CCXLB1H8R0ZAG	CERAMIC 8P D 50V		C7229	CKXLB1C104YAG	CERAMIC 0.1U K 16V	
C7201	CCXAV1H8R0AAG	CERAMIC 8P D 50V		C7229	CK1C104KGQBNG	CERAMIC 0.1U K 16V	
C7201	CCXLB1H8R0ZAG	CERAMIC 8P D 50V		C7230	CE0J220MKNANG	ELECT 22U M 6.3V	
C7202	CE0J220MKNANG	ELECT 22U M 6.3V		C7230	CE0J220M1WANG	ELECT 22U M 6.3V	
C7202	CE0J220M1WANG	ELECT 22U M 6.3V		C7231	CKXAV1C104EAG	CERAMIC 0.1U K 16V	
C7204	CKXAV1C104EAG	CERAMIC 0.1U K 16V		C7231	CKXLB1C104YAG	CERAMIC 0.1U K 16V	
C7204	CKXLB1C104YAG	CERAMIC 0.1U K 16V		C7231	CK1C104KGQBNG	CERAMIC 0.1U K 16V	
C7204	CK1C104KGQBNG	CERAMIC 0.1U K 16V		C7232	CKXAV1C104EAG	CERAMIC 0.1U K 16V	
C7205	CKXAV1C104EAG	CERAMIC 0.1U K 16V		C7232	CKXLB1C104YAG	CERAMIC 0.1U K 16V	
C7205	CKXLB1C104YAG	CERAMIC 0.1U K 16V		C7232	CK1C104KGQBNG	CERAMIC 0.1U K 16V	
C7205	CK1C104KGQBNG	CERAMIC 0.1U K 16V		C7233	CKXAV1C104EAG	CERAMIC 0.1U K 16V	
C7207	CE0J220MKNANG	ELECT 22U M 6.3V		C7233	CKXLB1C104YAG	CERAMIC 0.1U K 16V	
C7207	CE0J220M1WANG	ELECT 22U M 6.3V		C7233	CK1C104KGQBNG	CERAMIC 0.1U K 16V	
C7208	CE0J220MKNANG	ELECT 22U M 6.3V		C7234	CKXAV1C104EAG	CERAMIC 0.1U K 16V	
C7208	CE0J220M1WANG	ELECT 22U M 6.3V		C7234	CKXLB1C104YAG	CERAMIC 0.1U K 16V	
C7209	CE0J220MKNANG	ELECT 22U M 6.3V		C7234	CK1C104KGQBNG	CERAMIC 0.1U K 16V	
C7209	CE0J220M1WANG	ELECT 22U M 6.3V		C7235	CKXAV1C104EAG	CERAMIC 0.1U K 16V	
C7210	CKXAV1C104EAG	CERAMIC 0.1U K 16V		C7235	CKXLB1C104YAG	CERAMIC 0.1U K 16V	
C7210	CKXLB1C104YAG	CERAMIC 0.1U K 16V		C7235	CK1C104KGQBNG	CERAMIC 0.1U K 16V	
C7210	CK1C104KGQBNG	CERAMIC 0.1U K 16V		C7236	CCXAV1H100ABG	CERAMIC 10PJ 50.0V	
C7211	CKXAV1C104EAG	CERAMIC 0.1U K 16V		C7236	CCXLB1H100ZBG	CERAMIC 10P J 50V	
C7211	CKXLB1C104YAG	CERAMIC 0.1U K 16V		C7238	CE0J220MKNANG	ELECT 22U M 6.3V	
C7211	CK1C104KGQBNG	CERAMIC 0.1U K 16V		C7238	CE0J220M1WANG	ELECT 22U M 6.3V	
C7212	CKXAV1C104EAG	CERAMIC 0.1U K 16V		C7239	CKXAV1C104EAG	CERAMIC 0.1U K 16V	
C7212	CKXLB1C104YAG	CERAMIC 0.1U K 16V		C7239	CKXLB1C104YAG	CERAMIC 0.1U K 16V	
C7212	CK1C104KGQBNG	CERAMIC 0.1U K 16V		C7239	CK1C104KGQBNG	CERAMIC 0.1U K 16V	
C7213	CKXAV1C104EAG	CERAMIC 0.1U K 16V		C7240	CE0J220MKNANG	ELECT 22U M 6.3V	
C7213	CKXLB1C104YAG	CERAMIC 0.1U K 16V		C7240	CE0J220M1WANG	ELECT 22U M 6.3V	
C7213	CK1C104KGQBNG	CERAMIC 0.1U K 16V		C7241	CKXAV1C104EAG	CERAMIC 0.1U K 16V	
C7214	CE0J220MKNANG	ELECT 22U M 6.3V		C7241	CKXLB1C104YAG	CERAMIC 0.1U K 16V	
C7214	CE0J220M1WANG	ELECT 22U M 6.3V		C7241	CK1C104KGQBNG	CERAMIC 0.1U K 16V	
C7215	CE0J220MKNANG	ELECT 22U M 6.3V		C7242	CE0J220MKNANG	ELECT 22U M 6.3V	
C7215	CE0J220M1WANG	ELECT 22U M 6.3V		C7242	CE0J220M1WANG	ELECT 22U M 6.3V	
C7216	CKXAV1C104EAG	CERAMIC 0.1U K 16V		C7243	CKXAV1C104EAG	CERAMIC 0.1U K 16V	
C7216	CKXLB1C104YAG	CERAMIC 0.1U K 16V		C7243	CKXLB1C104YAG	CERAMIC 0.1U K 16V	
C7216	CK1C104KGQBNG	CERAMIC 0.1U K 16V		C7243	CK1C104KGQBNG	CERAMIC 0.1U K 16V	
C7217	CKXAV1C104EAG	CERAMIC 0.1U K 16V		C7244	CKXAV1C104EAG	CERAMIC 0.1U K 16V	
C7217	CKXLB1C104YAG	CERAMIC 0.1U K 16V		C7244	CKXLB1C104YAG	CERAMIC 0.1U K 16V	
C7217	CK1C104KGQBNG	CERAMIC 0.1U K 16V		C7244	CK1C104KGQBNG	CERAMIC 0.1U K 16V	
C7218	CKXAV1C104EAG	CERAMIC 0.1U K 16V		C7245	CKXAV1H103EAG	CERAMIC 0.01U K 50V	
C7218	CKXLB1C104YAG	CERAMIC 0.1U K 16V		C7245	CKXLB1H103YAG	CERAMIC 0.01U K 50V	
C7218	CK1C104KGQBNG	CERAMIC 0.1U K 16V		C7245	CK1H103KGQBNG	CERAMIC 0.01U K 50V	
C7219	CKXAV1C104EAG	CERAMIC 0.1U K 16V		C7246	CCXAV1H100ABG	CERAMIC 10PJ 50.0V	
C7219	CKXLB1C104YAG	CERAMIC 0.1U K 16V		C7246	CCXLB1H100ZBG	CERAMIC 10P J 50V	
C7219	CK1C104KGQBNG	CERAMIC 0.1U K 16V		C7248	CE0J220MKNANG	ELECT 22U M 6.3V	
C7220	CKXAV1C104EAG	CERAMIC 0.1U K 16V		C7248	CE0J220M1WANG	ELECT 22U M 6.3V	
C7220	CKXLB1C104YAG	CERAMIC 0.1U K 16V		C7249	CKXAV1C104EAG	CERAMIC 0.1U K 16V	
C7220	CK1C104KGQBNG	CERAMIC 0.1U K 16V		C7249	CKXLB1C104YAG	CERAMIC 0.1U K 16V	
C7221	CKXAV1C104EAG	CERAMIC 0.1U K 16V		C7249	CK1C104KGQBNG	CERAMIC 0.1U K 16V	
C7221	CKXLB1C104YAG	CERAMIC 0.1U K 16V		C7250	CE0J220MKNANG	ELECT 22U M 6.3V	
C7221	CK1C104KGQBNG	CERAMIC 0.1U K 16V		C7250	CE0J220M1WANG	ELECT 22U M 6.3V	
C7222	CKXAV1C104EAG	CERAMIC 0.1U K 16V		C7251	CE0J220MKNANG	ELECT 22U M 6.3V	
C7222	CKXLB1C104YAG	CERAMIC 0.1U K 16V		C7251	CE0J220M1WANG	ELECT 22U M 6.3V	
C7222	CK1C104KGQBNG	CERAMIC 0.1U K 16V		C7252	CKXAV1H103EAG	CERAMIC 0.01U K 50V	
C7223	CKXAV1C104EAG	CERAMIC 0.1U K 16V		C7252	CKXLB1H103YAG	CERAMIC 0.01U K 50V	
C7223	CKXLB1C104YAG	CERAMIC 0.1U K 16V		C7252	CK1H103KGQBNG	CERAMIC 0.01U K 50V	
C7223	CK1C104KGQBNG	CERAMIC 0.1U K 16V		C7253	CKXAV1H103EAG	CERAMIC 0.01U K 50V	
C7224	CKXAV1C104EAG	CERAMIC 0.1U K 16V		C7253	CKXLB1H103YAG	CERAMIC 0.01U K 50V	
C7224	CKXLB1C104YAG	CERAMIC 0.1U K 16V		C7253	CK1H103KGQBNG	CERAMIC 0.01U K 50V	
C7224	CK1C104KGQBNG	CERAMIC 0.1U K 16V		C7254	CKXAV1C104EAG	CERAMIC 0.1U K 16V	
C7225	CKXAV1C104EAG	CERAMIC 0.1U K 16V		C7254	CKXLB1C104YAG	CERAMIC 0.1U K 16V	
C7225	CKXLB1C104YAG	CERAMIC 0.1U K 16V		C7254	CK1C104KGQBNG	CERAMIC 0.1U K 16V	
C7225	CK1C104KGQBNG	CERAMIC 0.1U K 16V		C7255	CKXAV1C104EAG	CERAMIC 0.1U K 16V	
C7227	CKXAV1C104EAG	CERAMIC 0.1U K 16V		C7255	CKXLB1C104YAG	CERAMIC 0.1U K 16V	
C7227	CKXLB1C104YAG	CERAMIC 0.1U K 16V		C7255	CK1C104KGQBNG	CERAMIC 0.1U K 16V	

Ref. No.	Part No.	Description	Safety	Ref. No.	Part No.	Description	Safety
C7256	CKXAV1C104EAG	CERAMIC	0.1U K 16V	C7301	CK1E104ZGQFNG	CERAMIC	0.1U Z 25V
C7256	CKXLB1C104YAG	CERAMIC	0.1U K 16V	C7302	CKXLB1E104YDG	CERAMIC	0.1U Z 25V
C7256	CK1C104KGQBNG	CERAMIC	0.1U K 16V	C7302	CK1E104ZGQFNG	CERAMIC	0.1U Z 25V
C7257	CKXAV1C104EAG	CERAMIC	0.1U K 16V	C7303	CKXLB1E104YDG	CERAMIC	0.1U Z 25V
C7257	CKXLB1C104YAG	CERAMIC	0.1U K 16V	C7303	CK1E104ZGQFNG	CERAMIC	0.1U Z 25V
C7257	CK1C104KGQBNG	CERAMIC	0.1U K 16V	C7311	CE0J220MKNANG	ELECT	22U M 6.3V
C7258	CKXAV1C104EAG	CERAMIC	0.1U K 16V	C7311	CE0J220M1WANG	ELECT	22U M 6.3V
C7258	CKXLB1C104YAG	CERAMIC	0.1U K 16V	C7312	CKXAV1C104EAG	CERAMIC	0.1U K 16V
C7258	CK1C104KGQBNG	CERAMIC	0.1U K 16V	C7312	CKXLB1C104YAG	CERAMIC	0.1U K 16V
C7259	CKXAV1C104EAG	CERAMIC	0.1U K 16V	C7312	CK1C104KGQBNG	CERAMIC	0.1U K 16V
C7259	CKXLB1C104YAG	CERAMIC	0.1U K 16V	C7313	CKXAV1C104EAG	CERAMIC	0.1U K 16V
C7259	CK1C104KGQBNG	CERAMIC	0.1U K 16V	C7313	CKXLB1C104YAG	CERAMIC	0.1U K 16V
C7260	CKXAV1C104EAG	CERAMIC	0.1U K 16V	C7313	CK1C104KGQBNG	CERAMIC	0.1U K 16V
C7260	CKXLB1C104YAG	CERAMIC	0.1U K 16V	C7314	CKXAV1C104EAG	CERAMIC	0.1U K 16V
C7260	CK1C104KGQBNG	CERAMIC	0.1U K 16V	C7314	CKXLB1C104YAG	CERAMIC	0.1U K 16V
C7261	CE0J220MKNANG	ELECT	22U M 6.3V	C7314	CK1C104KGQBNG	CERAMIC	0.1U K 16V
C7261	CE0J220M1WANG	ELECT	22U M 6.3V	C7315	CKXAV1C104EAG	CERAMIC	0.1U K 16V
C7262	CKXAV1C104EAG	CERAMIC	0.1U K 16V	C7315	CKXLB1C104YAG	CERAMIC	0.1U K 16V
C7262	CKXLB1C104YAG	CERAMIC	0.1U K 16V	C7315	CK1C104KGQBNG	CERAMIC	0.1U K 16V
C7262	CK1C104KGQBNG	CERAMIC	0.1U K 16V	C7316	CKXAV1C104EAG	CERAMIC	0.1U K 16V
C7263	CKXAV1C104EAG	CERAMIC	0.1U K 16V	C7316	CKXLB1C104YAG	CERAMIC	0.1U K 16V
C7263	CKXLB1C104YAG	CERAMIC	0.1U K 16V	C7316	CK1C104KGQBNG	CERAMIC	0.1U K 16V
C7263	CK1C104KGQBNG	CERAMIC	0.1U K 16V	C7317	CKXAV1C104EAG	CERAMIC	0.1U K 16V
C7267	CKXAV1C104EAG	CERAMIC	0.1U K 16V	C7317	CKXLB1C104YAG	CERAMIC	0.1U K 16V
C7267	CKXLB1C104YAG	CERAMIC	0.1U K 16V	C7317	CK1C104KGQBNG	CERAMIC	0.1U K 16V
C7267	CK1C104KGQBNG	CERAMIC	0.1U K 16V	C7318	CKXAV1C104EAG	CERAMIC	0.1U K 16V
C7269	CKXAV1C104EAG	CERAMIC	0.1U K 16V	C7318	CKXLB1C104YAG	CERAMIC	0.1U K 16V
C7269	CKXLB1C104YAG	CERAMIC	0.1U K 16V	C7318	CK1C104KGQBNG	CERAMIC	0.1U K 16V
C7269	CK1C104KGQBNG	CERAMIC	0.1U K 16V	C7319	CKXAV1C104EAG	CERAMIC	0.1U K 16V
C7270	CKXAV1C104EAG	CERAMIC	0.1U K 16V	C7319	CKXLB1C104YAG	CERAMIC	0.1U K 16V
C7270	CKXLB1C104YAG	CERAMIC	0.1U K 16V	C7319	CK1C104KGQBNG	CERAMIC	0.1U K 16V
C7270	CK1C104KGQBNG	CERAMIC	0.1U K 16V	C7320	CKXAV1C104EAG	CERAMIC	0.1U K 16V
C7271	CKXAV1C104EAG	CERAMIC	0.1U K 16V	C7320	CKXLB1C104YAG	CERAMIC	0.1U K 16V
C7271	CKXLB1C104YAG	CERAMIC	0.1U K 16V	C7320	CK1C104KGQBNG	CERAMIC	0.1U K 16V
C7271	CK1C104KGQBNG	CERAMIC	0.1U K 16V	C7321	CKXAV1C104EAG	CERAMIC	0.1U K 16V
C7272	CKXAV1C104EAG	CERAMIC	0.1U K 16V	C7321	CKXLB1C104YAG	CERAMIC	0.1U K 16V
C7272	CKXLB1C104YAG	CERAMIC	0.1U K 16V	C7321	CK1C104KGQBNG	CERAMIC	0.1U K 16V
C7272	CK1C104KGQBNG	CERAMIC	0.1U K 16V	C7322	CE1C220MKNANG	ELECT	22U M 16V
C7273	CKXAV1E104EAG	CERAMIC	0.1U K 25V	C7322	CE1C220M1WANG	ELECT	22U M 16V
C7273	CKXLB1E104YAG	CERAMIC	0.1U K 25V	C7323	CKXAV1C104EAG	CERAMIC	0.1U K 16V
C7273	CK1E104KGQBNG	CERAMIC	0.1U K 25V	C7323	CKXLB1C104YAG	CERAMIC	0.1U K 16V
C7279	CKXLB1E104YDG	CERAMIC	0.1U Z 25V	C7323	CK1C104KGQBNG	CERAMIC	0.1U K 16V
C7279	CK1E104ZGQFNG	CERAMIC	0.1U Z 25V	C7324	CKXAV1C104EAG	CERAMIC	0.1U K 16V
C7280	CKXLB1E104YDG	CERAMIC	0.1U Z 25V	C7324	CKXLB1C104YAG	CERAMIC	0.1U K 16V
C7280	CK1E104ZGQFNG	CERAMIC	0.1U Z 25V	C7324	CK1C104KGQBNG	CERAMIC	0.1U K 16V
C7281	CKXLB1E104YDG	CERAMIC	0.1U Z 25V	C7500	CE1C470MKNANG	ELECT	47U M 16V
C7281	CK1E104ZGQFNG	CERAMIC	0.1U Z 25V	C7500	CE1C470M1WANG	ELECT	47U M 16V
C7282	CCXAV1H300ABG	CERAMIC30PJ	50.0V	C7501	CKXAV1C104EAG	CERAMIC	0.1U K 16V
C7282	CCXLB1H300ZBG	CERAMIC	30P J 50V	C7501	CKXLB1C104YAG	CERAMIC	0.1U K 16V
C7282	CC1H300JGQCNG	CERAMIC	30P J 50V	C7501	CK1C104KGQBNG	CERAMIC	0.1U K 16V
C7285	CK1A105MLZBNG	CERAMIC	1U M 10V	C7502	CKXAV1C104EAG	CERAMIC	0.1U K 16V
C7286	CK1A105MLZBNG	CERAMIC	1U M 10V	C7502	CKXLB1C104YAG	CERAMIC	0.1U K 16V
C7287	CEXLB1C100VAG	ELECT	10U M 16V	C7502	CK1C104KGQBNG	CERAMIC	0.1U K 16V
C7287	CE1C100M1WANG	ELECT	10U M 16V	C7503	CE1C470MKNANG	ELECT	47U M 16V
C7290	CCXAV1H101ABG	CERAMIC0.0001U J	50.0V	C7503	CE1C470M1WANG	ELECT	47U M 16V
C7290	CCXLB1H101ZBG	CERAMIC	100P J 50V	C7505	CKXAV1C104EAG	CERAMIC	0.1U K 16V
C7291	CCXAV1H101ABG	CERAMIC0.0001U J	50.0V	C7505	CKXLB1C104YAG	CERAMIC	0.1U K 16V
C7291	CCXLB1H101ZBG	CERAMIC	100P J 50V	C7505	CK1C104KGQBNG	CERAMIC	0.1U K 16V
C7296	CKXLB1E104YDG	CERAMIC	0.1U Z 25V	C7506	CKXAV1C104EAG	CERAMIC	0.1U K 16V
C7296	CK1E104ZGQFNG	CERAMIC	0.1U Z 25V	C7506	CKXLB1C104YAG	CERAMIC	0.1U K 16V
C7297	CKXLB1E104YDG	CERAMIC	0.1U Z 25V	C7506	CK1C104KGQBNG	CERAMIC	0.1U K 16V
C7297	CK1E104ZGQFNG	CERAMIC	0.1U Z 25V	C7507	CE1C470MKNANG	ELECT	47U M 16V
C7298	CKXLB1E104YDG	CERAMIC	0.1U Z 25V	C7507	CE1C470M1WANG	ELECT	47U M 16V
C7298	CK1E104ZGQFNG	CERAMIC	0.1U Z 25V	C7508	CE0J220MKNANG	ELECT	22U M 6.3V
C7299	CKXLB1E104YDG	CERAMIC	0.1U Z 25V	C7508	CE0J220M1WANG	ELECT	22U M 6.3V
C7299	CK1E104ZGQFNG	CERAMIC	0.1U Z 25V	C7509	CKXAV1C104EAG	CERAMIC	0.1U K 16V
C7300	CKXLB1E104YDG	CERAMIC	0.1U Z 25V	C7509	CKXLB1C104YAG	CERAMIC	0.1U K 16V
C7300	CK1E104ZGQFNG	CERAMIC	0.1U Z 25V	C7509	CK1C104KGQBNG	CERAMIC	0.1U K 16V
C7301	CKXLB1E104YDG	CERAMIC	0.1U Z 25V	C7510	CKXAV1C104EAG	CERAMIC	0.1U K 16V

Ref. No.	Part No.	Description	Safety	Ref. No.	Part No.	Description	Safety
C7510	CKXLB1C104YAG	CERAMIC	0.1U K 16V	C7536	CEXLB1C100VAG	ELECT	10U M 16V
C7510	CK1C104KGQBNG	CERAMIC	0.1U K 16V	C7536	CE1C100M1WANG	ELECT	10U M 16V
C7511	CKXAV1C104EAG	CERAMIC	0.1U K 16V	C7537	CKXAV1C104EAG	CERAMIC	0.1U K 16V
C7511	CKXLB1C104YAG	CERAMIC	0.1U K 16V	C7537	CKXLB1C104YAG	CERAMIC	0.1U K 16V
C7511	CK1C104KGQBNG	CERAMIC	0.1U K 16V	C7537	CK1C104KGQBNG	CERAMIC	0.1U K 16V
C7512	CKXAV1C104EAG	CERAMIC	0.1U K 16V	C7538	CEXLB1C100VAG	ELECT	10U M 16V
C7512	CKXLB1C104YAG	CERAMIC	0.1U K 16V	C7538	CE1C100M1WANG	ELECT	10U M 16V
C7512	CK1C104KGQBNG	CERAMIC	0.1U K 16V	C7539	CEXLB1C100VAG	ELECT	10U M 16V
C7513	CKXAV1H102EAG	CERAMIC	1000P K 50V	C7539	CE1C100M1WANG	ELECT	10U M 16V
C7513	CKXLB1H102YAG	CERAMIC	1000P K 50V	C7540	CKXAV1C104EAG	CERAMIC	0.1U K 16V
C7514	CKXAV1H102EAG	CERAMIC	1000P K 50V	C7540	CKXLB1C104YAG	CERAMIC	0.1U K 16V
C7514	CKXLB1H102YAG	CERAMIC	1000P K 50V	C7540	CK1C104KGQBNG	CERAMIC	0.1U K 16V
C7515	CKXAV1H102EAG	CERAMIC	1000P K 50V	C7541	CKXAV1H103EAG	CERAMIC	0.01U K 50V
C7515	CKXLB1H102YAG	CERAMIC	1000P K 50V	C7541	CKXLB1H103YAG	CERAMIC	0.01U K 50V
C7516	CKXAV1H102EAG	CERAMIC	1000P K 50V	C7541	CK1H103KGQBNG	CERAMIC	0.01U K 50V
C7516	CKXLB1H102YAG	CERAMIC	1000P K 50V	C7542	CEXLB1C100VAG	ELECT	10U M 16V
C7517	CKXAV1C104EAG	CERAMIC	0.1U K 16V	C7542	CE1C100M1WANG	ELECT	10U M 16V
C7517	CKXLB1C104YAG	CERAMIC	0.1U K 16V	C7543	CEXLB1C100VAG	ELECT	10U M 16V
C7517	CK1C104KGQBNG	CERAMIC	0.1U K 16V	C7543	CE1C100M1WANG	ELECT	10U M 16V
C7518	CKXAV1C104EAG	CERAMIC	0.1U K 16V	C7544	CKXAV1H103EAG	CERAMIC	0.01U K 50V
C7518	CKXLB1C104YAG	CERAMIC	0.1U K 16V	C7544	CKXLB1H103YAG	CERAMIC	0.01U K 50V
C7518	CK1C104KGQBNG	CERAMIC	0.1U K 16V	C7544	CK1H103KGQBNG	CERAMIC	0.01U K 50V
C7519	CKXAV1C104EAG	CERAMIC	0.1U K 16V	C7545	CKXAV1C104EAG	CERAMIC	0.1U K 16V
C7519	CKXLB1C104YAG	CERAMIC	0.1U K 16V	C7545	CKXLB1C104YAG	CERAMIC	0.1U K 16V
C7519	CK1C104KGQBNG	CERAMIC	0.1U K 16V	C7545	CK1C104KGQBNG	CERAMIC	0.1U K 16V
C7520	CKXAV1C104EAG	CERAMIC	0.1U K 16V	C8001	CKXAV1C104EAG	CERAMIC	0.1U K 16V
C7520	CKXLB1C104YAG	CERAMIC	0.1U K 16V	C8001	CKXLB1C104YAG	CERAMIC	0.1U K 16V
C7520	CK1C104KGQBNG	CERAMIC	0.1U K 16V	C8001	CK1C104KGQBNG	CERAMIC	0.1U K 16V
C7521	CKXAV1C104EAG	CERAMIC	0.1U K 16V	C8002	CKXAV1C104EAG	CERAMIC	0.1U K 16V
C7521	CKXLB1C104YAG	CERAMIC	0.1U K 16V	C8002	CKXLB1C104YAG	CERAMIC	0.1U K 16V
C7521	CK1C104KGQBNG	CERAMIC	0.1U K 16V	C8002	CK1C104KGQBNG	CERAMIC	0.1U K 16V
C7522	CKXAV1C104EAG	CERAMIC	0.1U K 16V	C8006	CKXAV1H222EAG	CERAMIC	0.0022U K 50V
C7522	CKXLB1C104YAG	CERAMIC	0.1U K 16V	C8006	CKXLB1H222YAG	CERAMIC	2200P K 50V
C7522	CK1C104KGQBNG	CERAMIC	0.1U K 16V	C8017	CEXLB1C100VAG	ELECT	10U M 16V
C7523	CKXAV1C104EAG	CERAMIC	0.1U K 16V	C8017	CE1C100MKNANG	ELECT	10U M 16V
C7523	CKXLB1C104YAG	CERAMIC	0.1U K 16V	C8017	CE1C100M1WANG	ELECT	10U M 16V
C7523	CK1C104KGQBNG	CERAMIC	0.1U K 16V	C8055	CCXAV1H100ABG	CERAMIC	10PJ 50.0V
C7524	CKXAV1C104EAG	CERAMIC	0.1U K 16V	C8055	CCXLB1H100ZBG	CERAMIC	10P J 50V
C7524	CKXLB1C104YAG	CERAMIC	0.1U K 16V	C8200	CE1C471MKNANG	ELECT	470U M 16V
C7524	CK1C104KGQBNG	CERAMIC	0.1U K 16V	C8200	CE1C471M1WANG	ELECT	470U M 16V
C7525	CKXAV1C104EAG	CERAMIC	0.1U K 16V	C8201	CE1C471MKNANG	ELECT	470U M 16V
C7525	CKXLB1C104YAG	CERAMIC	0.1U K 16V	C8201	CE1C471M1WANG	ELECT	470U M 16V
C7525	CK1C104KGQBNG	CERAMIC	0.1U K 16V	C8202	CKXAV1C104EAG	CERAMIC	0.1U K 16V
C7526	CKXAV1C104EAG	CERAMIC	0.1U K 16V	C8202	CKXLB1C104YAG	CERAMIC	0.1U K 16V
C7526	CKXLB1C104YAG	CERAMIC	0.1U K 16V	C8202	CK1C104KGQBNG	CERAMIC	0.1U K 16V
C7526	CK1C104KGQBNG	CERAMIC	0.1U K 16V	D001	DDXLBB053---G	DIODE	1SS35
C7527	CKXAV1C104EAG	CERAMIC	0.1U K 16V	D001	DD1SS355----G	DIODE	1SS355-TE-17
C7527	CKXLB1C104YAG	CERAMIC	0.1U K 16V	D002	DDXLBB053---G	DIODE	1SS35
C7527	CK1C104KGQBNG	CERAMIC	0.1U K 16V	D002	DD1SS355----G	DIODE	1SS355-TE-17
C7528	CKXAV1C104EAG	CERAMIC	0.1U K 16V	D006	DZUDZS10B---G	ZENER DIODE	UDZS-TE-1710B
C7528	CKXLB1C104YAG	CERAMIC	0.1U K 16V	D1500	DDXLBB053---G	DIODE	1SS35
C7528	CK1C104KGQBNG	CERAMIC	0.1U K 16V	D1500	DD1SS355----G	DIODE	1SS355-TE-17
C7529	CKXAV1C104EAG	CERAMIC	0.1U K 16V	D1501	DDXLBB053---G	DIODE	1SS35
C7529	CKXLB1C104YAG	CERAMIC	0.1U K 16V	D1501	DD1SS355----G	DIODE	1SS355-TE-17
C7529	CK1C104KGQBNG	CERAMIC	0.1U K 16V	D1502	DDXLBB053---G	DIODE	1SS35
C7530	CKXAV1C104EAG	CERAMIC	0.1U K 16V	D1502	DD1SS355----G	DIODE	1SS355-TE-17
C7530	CKXLB1C104YAG	CERAMIC	0.1U K 16V	D2205	DDXLBB053---G	DIODE	1SS35
C7530	CK1C104KGQBNG	CERAMIC	0.1U K 16V	D2205	DD1SS355----G	DIODE	1SS355-TE-17
C7531	CKXAV1C104EAG	CERAMIC	0.1U K 16V	D2208	DDXLBB053---G	DIODE	1SS35
C7531	CKXLB1C104YAG	CERAMIC	0.1U K 16V	D2208	DD1SS355----G	DIODE	1SS355-TE-17
C7531	CK1C104KGQBNG	CERAMIC	0.1U K 16V	D2209	DDDCC010----P	DIODE	DCC010-TB
C7532	CEXLB1C100VAG	ELECT	10U M 16V	D2301	DDDCC010----P	DIODE	DCC010-TB
C7532	CE1C100M1WANG	ELECT	10U M 16V	D7200	DDXLBB053---G	DIODE	1SS35
C7533	CKXLB1C104YAG	CERAMIC	0.1U K 16V	D7200	DD1SS355----G	DIODE	1SS355-TE-17
C7533	CK1C104KGQBNG	CERAMIC	0.1U K 16V	D7202	DDXLBB053---G	DIODE	1SS35
C7534	CCXAV1H220ABG	CERAMIC	22P J 50.0V	D7202	DD1SS355----G	DIODE	1SS355-TE-17
C7534	CCXLB1H220ZBG	CERAMIC	22P J 50V	D7204	DZUDZS5.6B--G	ZD	UDZS-TE-175.6B
C7535	CCXAV1H220ABG	CERAMIC	22P J 50.0V	D7204	DZXLBX5.6B-G	ZENER DIODE	MM3Z5V6B
C7535	CCXLB1H220ZBG	CERAMIC	22P J 50V	D7205	DZUDZS5.6B--G	ZD	UDZS-TE-175.6B

Ref. No.	Part No.	Description	Safety	Ref. No.	Part No.	Description	Safety
D7205	DZXLBxB5.6B-G	ZENER DIODE MM3Z5V6B		L7500	1AV4L26B2770G	INDUCTOR,220 OHM	
D7280	DDXLBB053---G	DIODE 1SS35		L7500	1LB4L26B0740G	INDUCTOR , 220 OHM	
D7280	DD1SS355----G	DIODE 1SS355-TE-17		L7501	1AV4L26B2770G	INDUCTOR,220 OHM	
D7500	DDXLBB053---G	DIODE 1SS35		L7501	1LB4L26B0740G	INDUCTOR , 220 OHM	
D7500	DD1SS355----G	DIODE 1SS355-TE-17		L7502	1AV4L26B2770G	INDUCTOR,220 OHM	
D7502	DDXLBB053---G	DIODE 1SS35		L7502	1LB4L26B0740G	INDUCTOR , 220 OHM	
D7502	DD1SS355----G	DIODE 1SS355-TE-17		L7503	1AV4L26B2770G	INDUCTOR,220 OHM	
D7503	DDDCC010----P	DIODE DCC010-TB		L7503	1LB4L26B0740G	INDUCTOR , 220 OHM	
D7504	DDXLBB053---G	DIODE 1SS35		L8001	RGFR000ZTCANL	MT-GLAZE 0.000 ZA 1/10W	
D7504	DD1SS355----G	DIODE 1SS355-TE-17		L8002	RGFR000ZTCANL	MT-GLAZE 0.000 ZA 1/10W	
D7505	DDXLBB053---G	DIODE 1SS35		L8003	RGFR000ZTCANL	MT-GLAZE 0.000 ZA 1/10W	
D7505	DD1SS355----G	DIODE 1SS355-TE-17		L8006	RGFR000ZTCANL	MT-GLAZE 0.000 ZA 1/10W	
D8002	DZUDZS3.6B--G	ZENER DIODE UDZS3.6B-TE-17		L8007	RGFR000ZTCANL	MT-GLAZE 0.000 ZA 1/10W	
D8002	DZXLBxB3.6B-G	ZENER DIODE MM3Z3V6B		PB0001	1LG4B10Y0140A	PWB MAIN N5AV	
D8003	DZUDZS3.6B--G	ZENER DIODE UDZS3.6B-TE-17		Q001	TXXLBB006---P	TR MMBTSC3928R	
D8003	DZXLBxB3.6B-G	ZENER DIODE MM3Z3V6B		Q001	7T200220	TR 2SC2412K(P)-6	
D8101	DDXLBB053---G	DIODE 1SS35		Q002	TXXLBB006---P	TR MMBTSC3928R	
D8101	DD1SS355----G	DIODE 1SS355-TE-17		Q002	7T200220	TR 2SC2412K(P)-6	
D8102	DDXLBB053---G	DIODE 1SS35		Q003	TXXLBB006---P	TR MMBTSC3928R	
D8102	DD1SS355----G	DIODE 1SS355-TE-17		Q003	7T200220	TR 2SC2412K(P)-6	
IC2202	QXXAVC638---P	IC AMS1085CM-3.3		Q681	TXXLBB006---P	TR MMBTSC3928R	
IC2203	QAMS1085CM--P	IC AMS1085CM		Q681	7T200220	TR 2SC2412K(P)-6	
IC2301	QAMS1117-2.5P	IC AMS1117-2.5		Q7200	TXXLBB006---P	TR MMBTSC3928R	
IC403	QYDA138-----M	IC YDA138		Q7200	7T200220	TR 2SC2412K(P)-6	
IC7200	QFLI8531-BE-M	IC FLI8531-LF-BE		Q7201	TXXLBB005---P	TR MMBTSA1235F	
IC7203	Q24LC21A/SN-P	IC 24LC21AT/SN		Q7201	7T200221	TR 2SA1037K(P)-4	
IC7205	QXXAVC697---P	IC 74LVC14APW/G, 118		Q7203	TXXLBB006---P	TR MMBTSC3928R	
IC7300	QXXAVC914---M	IC K4D551638H-LC40		Q7203	7T200220	TR 2SC2412K(P)-6	
IC7500	QANX9011L---M	IC ANX9011L		Q7280	TTPC8109----P	TR TPC8109	
IC7501	QAMS1117-3.3P	IC AMS1117-3.3		Q7500	TXXLBB006---P	TR MMBTSC3928R	
IC7501	QLM1117S-3.3P	IC LM1117S-3.3		Q7500	7T200220	TR 2SC2412K(P)-6	
IC7502	QAMS1117-1.8P	IC AMS1117-1.8		Q8002	TXXLBB006---P	TR MMBTSC3928R	
IC7502	QLM1117S-1.8P	IC LM1117S-1.8		Q8002	7T200220	TR 2SC2412K(P)-6	
IC7503	Q24C02CT/SN-P	IC 24C02CT-I/SNG		Q8003	T2SK536-----P	TR 2SK536-TB	
IC7504	QCM2021----P	IC CM2021		Q8004	T2SK536-----P	TR 2SK536-TB	
IC7505	QCS4344-CZZ-P	IC CS4344-CZZ		Q8007	TXXLBB006---P	TR MMBTSC3928R	
IC8001	QXXAAJQ0810--	IC W25X80VSSIG-N5AV		Q8007	7T200220	TR 2SC2412K(P)-6	
IC8001A	QXXAVC909---P	IC W25X80VSSIG		Q8100	TXXLBB006---P	TR MMBTSC3928R	
IC8001B	1AA6P4P1588--	LABEL-W25X80VSSIG-N5AV		Q8100	7T200220	TR 2SC2412K(P)-6	
IC8002	Q24LC32AT/SNP	IC 24LC32AT-I/SNG		Q8102	TXXLBB005---P	TR MMBTSA1235F	
K1003	1LB4J12B06602	JACK,RCA-5(6-1)		Q8102	7T200221	TR 2SA1037K(P)-4	
K7204	1AV4J12B06800	JACK,PHONE D3.5		Q8103	TXXLBB006---P	TR MMBTSC3928R	
K7204	1LB4J12B11900	JACK,PHONE D3.6		Q8103	7T200220	TR 2SC2412K(P)-6	
L001	1LB4L26B0880N	INDUCTOR,22UH		Q8104	TXXLBB006---P	TR MMBTSC3928R	
L002	1LB4L26B0880N	INDUCTOR,22UH		Q8104	7T200220	TR 2SC2412K(P)-6	
L003	1LB4L26B0880N	INDUCTOR,22UH		RB7200	1AV4R1A43304G	R-NETWORK 33X4 0.063W	
L004	1LB4L26B0880N	INDUCTOR,22UH		RB7200	1LB4R1YA330JG	R-NETWORK 33X4 0.063W	
L2204	1AV4L26B2770G	INDUCTOR,220 OHM		RB7200	1LB4R1ZA330JG	R-NETWORK 33X4 0.063W	
L2204	1LB4L26B0740G	INDUCTOR , 220 OHM		RB7201	1AV4R1A43304G	R-NETWORK 33X4 0.063W	
L2205	1AV4L26B2770G	INDUCTOR,220 OHM		RB7201	1LB4R1YA330JG	R-NETWORK 33X4 0.063W	
L2205	1LB4L26B0740G	INDUCTOR , 220 OHM		RB7201	1LB4R1ZA330JG	R-NETWORK 33X4 0.063W	
L2206	1AV4L26B2770G	INDUCTOR,220 OHM		RB7202	1AV4R1A43304G	R-NETWORK 33X4 0.063W	
L2206	1LB4L26B0740G	INDUCTOR , 220 OHM		RB7202	1LB4R1YA330JG	R-NETWORK 33X4 0.063W	
L2207	1AV4L26B2770G	INDUCTOR,220 OHM		RB7202	1LB4R1ZA330JG	R-NETWORK 33X4 0.063W	
L2207	1LB4L26B0740G	INDUCTOR , 220 OHM		RB7203	1AV4R1A43304G	R-NETWORK 33X4 0.063W	
L2208	1AV4L26B2770G	INDUCTOR,220 OHM		RB7203	1LB4R1YA330JG	R-NETWORK 33X4 0.063W	
L2208	1LB4L26B0740G	INDUCTOR , 220 OHM		RB7203	1LB4R1ZA330JG	R-NETWORK 33X4 0.063W	
L2209	1AV4L26B2770G	INDUCTOR,220 OHM		RB7204	1AV4R1A43304G	R-NETWORK 33X4 0.063W	
L2209	1LB4L26B0740G	INDUCTOR , 220 OHM		RB7204	1LB4R1YA330JG	R-NETWORK 33X4 0.063W	
L2210	1AV4L26B2770G	INDUCTOR,220 OHM		RB7204	1LB4R1ZA330JG	R-NETWORK 33X4 0.063W	
L2210	1LB4L26B0740G	INDUCTOR , 220 OHM		RB7205	1AV4R1A43304G	R-NETWORK 33X4 0.063W	
L2211	1AV4L26B2770G	INDUCTOR,220 OHM		RB7205	1LB4R1YA330JG	R-NETWORK 33X4 0.063W	
L2211	1LB4L26B0740G	INDUCTOR , 220 OHM		RB7205	1LB4R1ZA330JG	R-NETWORK 33X4 0.063W	
L2212	1AV4L26B2770G	INDUCTOR,220 OHM		RB7500	1AV4R1A43304G	R-NETWORK 33X4 0.063W	
L2212	1LB4L26B0740G	INDUCTOR , 220 OHM		RB7500	1LB4R1YA330JG	R-NETWORK 33X4 0.063W	
L2213	1AV4L26B2770G	INDUCTOR,220 OHM		RB7500	1LB4R1ZA330JG	R-NETWORK 33X4 0.063W	
L2213	1LB4L26B0740G	INDUCTOR , 220 OHM		RB7501	1AV4R1A43304G	R-NETWORK 33X4 0.063W	
L7205	RGFR000ZTCANL	MT-GLAZE 0.000 ZA 1/10W		RB7501	1LB4R1YA330JG	R-NETWORK 33X4 0.063W	
L7206	RGFR000ZTCANL	MT-GLAZE 0.000 ZA 1/10W		RB7501	1LB4R1ZA330JG	R-NETWORK 33X4 0.063W	

Ref. No.	Part No.	Description	Safety	Ref. No.	Part No.	Description	Safety
RB7502	1AV4R1A43304G	R-NETWORK 33X4 0.063W		R7197	RGFR000ZTCANL	MT-GLAZE 0.000 ZA 1/10W	
RB7502	1LB4R1YA330JG	R-NETWORK 33X4 0.063W		R7198	RGF4701JTCANL	MT-GLAZE 4.7K JA 1/10W	
RB7502	1LB4R1ZA330JG	R-NETWORK 33X4 0.063W		R7199	RGF4701JTCANL	MT-GLAZE 4.7K JA 1/10W	
RB7503	1AV4R1A43304G	R-NETWORK 33X4 0.063W		R7200	RGF33R0JTCANL	MT-GLAZE 33 JA 1/10W	
RB7503	1LB4R1YA330JG	R-NETWORK 33X4 0.063W		R7201	RGF1002JTCANL	MT-GLAZE 10K JA 1/10W	
RB7503	1LB4R1ZA330JG	R-NETWORK 33X4 0.063W		R7202	RGF1002JTCANL	MT-GLAZE 10K JA 1/10W	
R001	RGF1001JTCANL	MT-GLAZE 1K JA 1/10W		R7204	RGF1002JTCANL	MT-GLAZE 10K JA 1/10W	
R002	RGF1002JTCANL	MT-GLAZE 10K JA 1/10W		R7208	RGF1002JTCANL	MT-GLAZE 10K JA 1/10W	
R003	RGF1003JTCANL	MT-GLAZE 100K JA 1/10W		R7211	RGF1002JTCANL	MT-GLAZE 10K JA 1/10W	
R004	RGFR000ZTCANL	MT-GLAZE 0.000 ZA 1/10W		R7212	RGF1002JTCANL	MT-GLAZE 10K JA 1/10W	
R006	RGFR000ZTCANL	MT-GLAZE 0.000 ZA 1/10W		R7213	RGF1000JTCANL	MT-GLAZE 100 JA 1/10W	
R007	RGF1003JTCANL	MT-GLAZE 100K JA 1/10W		R7214	RGF1000JTCANL	MT-GLAZE 100 JA 1/10W	
R008	RGF1001JTCANL	MT-GLAZE 1K JA 1/10W		R7215	RGF1000JTCANL	MT-GLAZE 100 JA 1/10W	
R013	RGKR000ZTFANL	MT-GLAZE 0.000 ZA 1/3W		R7216	RGF1000JTCANL	MT-GLAZE 100 JA 1/10W	
R014	RGKR000ZTFANL	MT-GLAZE 0.000 ZA 1/3W		R7217	RGF33R0JTCANL	MT-GLAZE 33 JA 1/10W	
R015	RGFR000ZTCANL	MT-GLAZE 0.000 ZA 1/10W		R7218	RGF33R0JTCANL	MT-GLAZE 33 JA 1/10W	
R017	RGKR000ZTFANL	MT-GLAZE 0.000 ZA 1/3W		R7219	RGF33R0JTCANL	MT-GLAZE 33 JA 1/10W	
R031	RGFR000ZTCANL	MT-GLAZE 0.000 ZA 1/10W		R7220	RGF33R0JTCANL	MT-GLAZE 33 JA 1/10W	
R032	RGF1000JTCANL	MT-GLAZE 100 JA 1/10W		R7221	RGF33R0JTCANL	MT-GLAZE 33 JA 1/10W	
R033	RGF4702JTCANL	MT-GLAZE 47K JA 1/10W		R7222	RGF33R0JTCANL	MT-GLAZE 33 JA 1/10W	
R034	RGFR000ZTCANL	MT-GLAZE 0.000 ZA 1/10W		R7223	RGF33R0JTCANL	MT-GLAZE 33 JA 1/10W	
R038	RGF2201JTCANL	MT-GLAZE 2.2K JA 1/10W		R7224	RGF33R0JTCANL	MT-GLAZE 33 JA 1/10W	
R039	RGFR000ZTCANL	MT-GLAZE 0.000 ZA 1/10W		R7225	RGF33R0JTCANL	MT-GLAZE 33 JA 1/10W	
R041	RGF1201JTCANL	MT-GLAZE 1.2K JA 1/10W		R7226	RGF33R0JTCANL	MT-GLAZE 33 JA 1/10W	
R042	RGF1201JTCANL	MT-GLAZE 1.2K JA 1/10W		R7227	RGF33R0JTCANL	MT-GLAZE 33 JA 1/10W	
R1031	RGFR000ZTCANL	MT-GLAZE 0.000 ZA 1/10W		R7228	RGF33R0JTCANL	MT-GLAZE 33 JA 1/10W	
R1033	RGFR000ZTCANL	MT-GLAZE 0.000 ZA 1/10W		R7229	RGF33R0JTCANL	MT-GLAZE 33 JA 1/10W	
R1034	RGFR000ZTCANL	MT-GLAZE 0.000 ZA 1/10W		R7230	RGF33R0JTCANL	MT-GLAZE 33 JA 1/10W	
R1035	RGF1003FTCANL	MT-GLAZE 100K FA 1/10W		R7231	RGF47R0JTCANL	MT-GLAZE 47 JA 1/10W	
R1036	RGFR000ZTCANL	MT-GLAZE 0.000 ZA 1/10W		R7232	RGF47R0JTCANL	MT-GLAZE 47 JA 1/10W	
R1038	RGFR000ZTCANL	MT-GLAZE 0.000 ZA 1/10W		R7233	RGF56R0JTCANL	MT-GLAZE 56 JA 1/10W	
R1039	RGF75R0JTCANL	MT-GLAZE 75 JA 1/10W		R7234	RGF56R0JTCANL	MT-GLAZE 56 JA 1/10W	
R1040	RGFR000ZTCANL	MT-GLAZE 0.000 ZA 1/10W		R7235	RGF56R0JTCANL	MT-GLAZE 56 JA 1/10W	
R1041	RGF1003JTCANL	MT-GLAZE 100K JA 1/10W		R7236	RGF56R0JTCANL	MT-GLAZE 56 JA 1/10W	
R1042	RGF75R0JTCANL	MT-GLAZE 75 JA 1/10W		R7237	RGF4701JTCANL	MT-GLAZE 4.7K JA 1/10W	
R1503	RGFR000ZTCANL	MT-GLAZE 0.000 ZA 1/10W		R7238	RGF4701JTCANL	MT-GLAZE 4.7K JA 1/10W	
R1504	RGF1002JTCANL	MT-GLAZE 10K JA 1/10W		R7240	RGFR000ZTCANL	MT-GLAZE 0.000 ZA 1/10W	
R1505	RGFR000ZTCANL	MT-GLAZE 0.000 ZA 1/10W		R7241	RGF4701JTCANL	MT-GLAZE 4.7K JA 1/10W	
R1578	RGKR000ZTFANL	MT-GLAZE 0.000 ZA 1/3W		R7242	RGF4701JTCANL	MT-GLAZE 4.7K JA 1/10W	
R2201	RGF8200FTCANL	MT-GLAZE 820 FA 1/10W		R7243	RGF75R0JTCANL	MT-GLAZE 75 JA 1/10W	
R2202	RGF3600FTCANL	MT-GLAZE 360 FA 1/10W		R7244	RGF75R0JTCANL	MT-GLAZE 75 JA 1/10W	
R2203	RG1R000ZTEANL	MT-GLAZE 0.000 ZA 1W		R7245	RGF75R0JTCANL	MT-GLAZE 75 JA 1/10W	
R7100	RGF1502JTCANL	MT-GLAZE 15K JA 1/10W		R7246	RGF22R0JTCANL	MT-GLAZE 22 JA 1/10W	
R7101	RGF1002JTCANL	MT-GLAZE 10K JA 1/10W		R7247	RGF22R0JTCANL	MT-GLAZE 22 JA 1/10W	
R7102	RGF22R0JTCANL	MT-GLAZE 22 JA 1/10W		R7248	RGF1000JTCANL	MT-GLAZE 100 JA 1/10W	
R7103	RGF1002JTCANL	MT-GLAZE 10K JA 1/10W		R7249	RGF22R0JTCANL	MT-GLAZE 22 JA 1/10W	
R7105	RGF1000JTCANL	MT-GLAZE 100 JA 1/10W		R7250	RGF1000JTCANL	MT-GLAZE 100 JA 1/10W	
R7116	RGK4701JTFANL	MT-GLAZE 4.7K JA 1/3W		R7251	RGF1000JTCANL	MT-GLAZE 100 JA 1/10W	
R7119	RGKR000ZTFANL	MT-GLAZE 0.000 ZA 1/3W		R7252	RGF1000JTCANL	MT-GLAZE 100 JA 1/10W	
R7138	RGKR000ZTFANL	MT-GLAZE 0.000 ZA 1/3W		R7253	RGF2702JTCANL	MT-GLAZE 27K JA 1/10W	
R7175	RGFR000ZTCANL	MT-GLAZE 0.000 ZA 1/10W		R7254	RGF4700FTCANL	MT-GLAZE 470 FA 1/10W	
R7176	RGF22R0JTCANL	MT-GLAZE 22 JA 1/10W		R7255	RGF1202JTCANL	MT-GLAZE 12K JA 1/10W	
R7177	RGF22R0JTCANL	MT-GLAZE 22 JA 1/10W		R7256	RGF2200JTCANL	MT-GLAZE 220 JA 1/10W	
R7178	RGF1001JTCANL	MT-GLAZE 1K JA 1/10W		R7257	RGF1000FTCANL	MT-GLAZE 100 FA 1/10W	
R7179	RGF22R0JTCANL	MT-GLAZE 22 JA 1/10W		R7258	RGF6800JTCANL	MT-GLAZE 680 JA 1/10W	
R7180	RGF22R0JTCANL	MT-GLAZE 22 JA 1/10W		R7259	RGF56R0JTCANL	MT-GLAZE 56 JA 1/10W	
R7181	RGF22R0JTCANL	MT-GLAZE 22 JA 1/10W		R7260	RGF1002JTCANL	MT-GLAZE 10K JA 1/10W	
R7182	RGF1000JTCANL	MT-GLAZE 100 JA 1/10W		R7261	RGF1000JTCANL	MT-GLAZE 100 JA 1/10W	
R7183	RGFR000ZTCANL	MT-GLAZE 0.000 ZA 1/10W		R7262	RGF1003JTCANL	MT-GLAZE 100K JA 1/10W	
R7184	RGFR000ZTCANL	MT-GLAZE 0.000 ZA 1/10W					
R7185	RGF22R0JTCANL	MT-GLAZE 22 JA 1/10W					
R7186	RGF1002JTCANL	MT-GLAZE 10K JA 1/10W					
R7187	RGF6801JTCANL	MT-GLAZE 6.8K JA 1/10W					
R7188	RGFR000ZTCANL	MT-GLAZE 0.000 ZA 1/10W					
R7189	RGFR000ZTCANL	MT-GLAZE 0.000 ZA 1/10W					
R7192	RGFR000ZTCANL	MT-GLAZE 0.000 ZA 1/10W					
R7193	RGKR000ZTFANL	MT-GLAZE 0.000 ZA 1/3W					
R7194	RGF1002JTCANL	MT-GLAZE 10K JA 1/10W					
R7196	RGFR000ZTCANL	MT-GLAZE 0.000 ZA 1/10W					









Ref. No.	Part No.	Description	Safety	Ref. No.	Part No.	Description	Safety
R7263	RGF1003JTCANL	MT-GLAZE 100K JA 1/10W		R8001	RGF1002JTCANL	MT-GLAZE 10K JA 1/10W	
R7266	RGFR000ZTCANL	MT-GLAZE 0.000 ZA 1/10W		R8002	RGFR000ZTCANL	MT-GLAZE 0.000 ZA 1/10W	
R7270	RGFR000ZTCANL	MT-GLAZE 0.000 ZA 1/10W		R8003	RGF1002JTCANL	MT-GLAZE 10K JA 1/10W	
R7272	RGFR000ZTCANL	MT-GLAZE 0.000 ZA 1/10W		R8004	RGF1002JTCANL	MT-GLAZE 10K JA 1/10W	
R7280	RGF22R0JTCANL	MT-GLAZE 22 JA 1/10W		R8005	RGF4701JTCANL	MT-GLAZE 4.7K JA 1/10W	
R7281	RGF22R0JTCANL	MT-GLAZE 22 JA 1/10W		R8006	RGF4701JTCANL	MT-GLAZE 4.7K JA 1/10W	
R7282	RGF22R0JTCANL	MT-GLAZE 22 JA 1/10W		R8007	RGF33R0JTCANL	MT-GLAZE 33 JA 1/10W	
R7283	RGF22R0JTCANL	MT-GLAZE 22 JA 1/10W		R8008	RGF1002JTCANL	MT-GLAZE 10K JA 1/10W	
R7284	RGF22R0JTCANL	MT-GLAZE 22 JA 1/10W		R8009	RGFR000ZTCANL	MT-GLAZE 0.000 ZA 1/10W	
R7285	RGF22R0JTCANL	MT-GLAZE 22 JA 1/10W		R8010	RGFR000ZTCANL	MT-GLAZE 0.000 ZA 1/10W	
R7286	RGF22R0JTCANL	MT-GLAZE 22 JA 1/10W		R8013	RGFR000ZTCANL	MT-GLAZE 0.000 ZA 1/10W	
R7287	RGF22R0JTCANL	MT-GLAZE 22 JA 1/10W		R8014	RGFR000ZTCANL	MT-GLAZE 0.000 ZA 1/10W	
R7290	RGF6801JTCANL	MT-GLAZE 6.8K JA 1/10W		R8015	RGF4702JTCANL	MT-GLAZE 47K JA 1/10W	
R7291	RGF4701JTCANL	MT-GLAZE 4.7K JA 1/10W		R8016	RGF4702JTCANL	MT-GLAZE 47K JA 1/10W	
R7292	RGF1002JTCANL	MT-GLAZE 10K JA 1/10W		R8017	RGFR000ZTCANL	MT-GLAZE 0.000 ZA 1/10W	
R7300	RGF2702JTCANL	MT-GLAZE 27K JA 1/10W		R8018	RGFR000ZTCANL	MT-GLAZE 0.000 ZA 1/10W	
R7307	RGFR000ZTCANL	MT-GLAZE 0.000 ZA 1/10W		R8020	RGF1002JTCANL	MT-GLAZE 10K JA 1/10W	
R7308	RGFR000ZTCANL	MT-GLAZE 0.000 ZA 1/10W		R8021	RGF4702JTCANL	MT-GLAZE 47K JA 1/10W	
R7310	RGF22R0JTCANL	MT-GLAZE 22 JA 1/10W		R8022	RGF4702JTCANL	MT-GLAZE 47K JA 1/10W	
R7311	RGF22R0JTCANL	MT-GLAZE 22 JA 1/10W		R8023	RGF4701JTCANL	MT-GLAZE 4.7K JA 1/10W	
R7312	RGF22R0JTCANL	MT-GLAZE 22 JA 1/10W		R8024	RGF2201JTCANL	MT-GLAZE 2.2K JA 1/10W	
R7319	RGF1002FTCANL	MT-GLAZE 10K FA 1/10W		R8025	RGF2701JTCANL	MT-GLAZE 2.7K JA 1/10W	
R7320	RGF1002FTCANL	MT-GLAZE 10K FA 1/10W		R8027	RGF1002JTCANL	MT-GLAZE 10K JA 1/10W	
R7326	RGKR000ZTFANL	MT-GLAZE 0.000 ZA 1/3W		R8028	RGF1002JTCANL	MT-GLAZE 10K JA 1/10W	
R7327	RGF1100JTCANL	MT-GLAZE 110 JA 1/10W		R8029	RGF1000JTCANL	MT-GLAZE 100 JA 1/10W	
R7328	RGF1500JTCANL	MT-GLAZE 150 JA 1/10W		R8030	RGF1002JTCANL	MT-GLAZE 10K JA 1/10W	
R7329	RGKR000ZTFANL	MT-GLAZE 0.000 ZA 1/3W		R8034	RGFR000ZTCANL	MT-GLAZE 0.000 ZA 1/10W	
R7332	RGF1000JTCANL	MT-GLAZE 100 JA 1/10W		R8038	RGF1001JTCANL	MT-GLAZE 1K JA 1/10W	
R7333	RGF1000JTCANL	MT-GLAZE 100 JA 1/10W		R8077	RGF1001JTCANL	MT-GLAZE 1K JA 1/10W	
R7359	RGFR000ZTCANL	MT-GLAZE 0.000 ZA 1/10W		R8079	RGF4700JTCANL	MT-GLAZE 470 JA 1/10W	
R7360	RGFR000ZTCANL	MT-GLAZE 0.000 ZA 1/10W		R8090	RGFR000ZTCANL	MT-GLAZE 0.000 ZA 1/10W	
R7361	RGFR000ZTCANL	MT-GLAZE 0.000 ZA 1/10W		R8098	RGF1004JTCANL	MT-GLAZE 1M JA 1/10W	
R7362	RGFR000ZTCANL	MT-GLAZE 0.000 ZA 1/10W		R8099	RGFR000ZTCANL	MT-GLAZE 0.000 ZA 1/10W	
R7380	RGF75R0JTCANL	MT-GLAZE 75 JA 1/10W		R8288	RGF1002JTCANL	MT-GLAZE 10K JA 1/10W	
R7381	RGF75R0JTCANL	MT-GLAZE 75 JA 1/10W		X7200	1LB4V10B0490G	OSC,CRYSTAL 19.6608MHZ	
R7383	RGF75R0JTCANL	MT-GLAZE 75 JA 1/10W		X7500	1AV4V10B8180N	OSC,CRYSTAL 27.0MHZ	
R7384	RGF75R0JTCANL	MT-GLAZE 75 JA 1/10W		X7500	1LB4V10B0480N	OSC,CRYSTAL 27.000MHZ	
R7500	RG1R000ZTEANL	MT-GLAZE 0.000 ZA 1W		A2000	1LG0B10Y01900	ASSY SUB-COMP N5AV	
R7502	RGF1000JTCANL	MT-GLAZE 100 JA 1/10W		A001	1LG0B10Y0190A	ASSY SUB N5AV	
R7505	RGF4701JTCANL	MT-GLAZE 4.7K JA 1/10W		A101	1AV4F1FAM0180	TUNER,TU/IF/DEC	
R7506	RGF4702JTCANL	MT-GLAZE 47K JA 1/10W		C101	CXLB1C100VDN	ELECT 10U M 16V	
R7507	RGFR000ZTCANL	MT-GLAZE 0.000 ZA 1/10W		C102	CCXAV1H680ABG	CERAMIC68PJ 50.0V	
R7508	RGFR000ZTCANL	MT-GLAZE 0.000 ZA 1/10W		C102	CCXLB1H680ZBG	CERAMIC 68P J 50V	
R7510	RGF33R0JTCANL	MT-GLAZE 33 JA 1/10W		C102	CC1H680JGQCNG	CERAMIC 68P J 50V	
R7511	RGF33R0JTCANL	MT-GLAZE 33 JA 1/10W		C103	CCXAV1H680ABG	CERAMIC68PJ 50.0V	
R7512	RGF1001JTCANL	MT-GLAZE 1K JA 1/10W		C103	CCXLB1H680ZBG	CERAMIC 68P J 50V	
R7513	RGF1004JTCANL	MT-GLAZE 1M JA 1/10W		C103	CC1H680JGQCNG	CERAMIC 68P J 50V	
R7515	RGF4701JTCANL	MT-GLAZE 4.7K JA 1/10W		C104	CCXAV1H680ABG	CERAMIC68PJ 50.0V	
R7516	RGF1000JTCANL	MT-GLAZE 100 JA 1/10W		C104	CCXLB1H680ZBG	CERAMIC 68P J 50V	
R7517	RGF1000JTCANL	MT-GLAZE 100 JA 1/10W		C104	CC1H680JGQCNG	CERAMIC 68P J 50V	
R7518	RGF1002JTCANL	MT-GLAZE 10K JA 1/10W		C105	CCXAV1H680ABG	CERAMIC68PJ 50.0V	
R7519	RGF33R0JTCANL	MT-GLAZE 33 JA 1/10W		C105	CCXLB1H680ZBG	CERAMIC 68P J 50V	
R7520	RGF33R0JTCANL	MT-GLAZE 33 JA 1/10W		C105	CC1H680JGQCNG	CERAMIC 68P J 50V	
R7521	RGF33R0JTCANL	MT-GLAZE 33 JA 1/10W		C106	CXLB1C101VDN	ELECT 100U M 16V	
R7522	RGF1000JTCANL	MT-GLAZE 100 JA 1/10W		C107	CKXLB1E104YDG	CERAMIC 0.1U Z 25V	
R7523	RGF1002JTCANL	MT-GLAZE 10K JA 1/10W		C107	CK1E104ZGQFNG	CERAMIC 0.1U Z 25V	
R7524	RGF3300JTCANL	MT-GLAZE 330 JA 1/10W		C108	CXLB1H101VDN	ELECT 100U M 50V	
R7525	RGF1000JTCANL	MT-GLAZE 100 JA 1/10W		C109	CKXLB1H104YAG	CERAMIC 0.1U K 50V	
R7526	RGF33R0JTCANL	MT-GLAZE 33 JA 1/10W		C109	CK1H104KGABNG	CERAMIC 0.1U K 50V	
R7527	RGF1004JTCANL	MT-GLAZE 1M JA 1/10W		C110	CKXLB1H103YAG	CERAMIC 0.01U K 50V	
R7528	RGF1000JTCANL	MT-GLAZE 100 JA 1/10W		C111	CPXLB1C220ZAN	NP-ELECT 22U M 16V	
R7529	RGF1000JTCANL	MT-GLAZE 100 JA 1/10W		C112	CXLB1C100VDN	ELECT 10U M 16V	
R7530	RGF1000JTCANL	MT-GLAZE 100 JA 1/10W		C113	CXLB1C100VDN	ELECT 10U M 16V	
R7531	RGF1000JTCANL	MT-GLAZE 100 JA 1/10W		C114	CXLB1E100VDN	ELECT 10U M 25V	
R7532	RGF1002JTCANL	MT-GLAZE 10K JA 1/10W		C115	CXLB1C100VDN	ELECT 10U M 16V	
R7533	RGF4700JTCANL	MT-GLAZE 470 JA 1/10W		C116	CXLB1C100VDN	ELECT 10U M 16V	
R7534	RGF4700JTCANL	MT-GLAZE 470 JA 1/10W		C117	CXLB1C101VDN	ELECT 100U M 16V	
R7535	RGF1002JTCANL	MT-GLAZE 10K JA 1/10W		C118	CKXLB1H104YDG	CERAMIC 0.1U Z 50V	
R7541	RGF4702JTCANL	MT-GLAZE 47K JA 1/10W		C118	CK1H104ZGQFNG	CERAMIC 0.1U Z 50V	

Ref. No.	Part No.	Description	Safety	Ref. No.	Part No.	Description	Safety
C119	CXLB1C101VDN	ELECT 100U M 16V		C328	CKXAV1C104EAG	CERAMIC 0.1U K 16V	
C120	CKXLB1H104YDG	CERAMIC 0.1U Z 50V		C328	CKXLB1C104YAG	CERAMIC 0.1U K 16V	
C120	CK1H104ZGQFNG	CERAMIC 0.1U Z 50V		C328	CK1C104KGQBNG	CERAMIC 0.1U K 16V	
C190	CXLB0J470VDN	ELECT 47U M 6.3V		C329	CKXAV1C104EAG	CERAMIC 0.1U K 16V	
C190	CXLB0J470WAN	ELECT 47U M 6.3V		C329	CKXLB1C104YAG	CERAMIC 0.1U K 16V	
C191	CKXLB1E104YDG	CERAMIC 0.1U Z 25V		C329	CK1C104KGQBNG	CERAMIC 0.1U K 16V	
C191	CK1E104ZGQFNG	CERAMIC 0.1U Z 25V		C330	CKXAV1C104EAG	CERAMIC 0.1U K 16V	
C192	CK1A105MLZBNG	CERAMIC 1U M 10V		C330	CKXLB1C104YAG	CERAMIC 0.1U K 16V	
C193	CKXAV1H103EAG	CERAMIC 0.01U K 50V		C330	CK1C104KGQBNG	CERAMIC 0.1U K 16V	
C193	CKXLB1H103YAG	CERAMIC 0.01U K 50V		C334	CKXAV1H104EAG	CERAMIC 0.1U K 50V	
C193	CK1H103KGQBNG	CERAMIC 0.01U K 50V		C334	CKXLB1H104YAG	CERAMIC 0.1U K 50V	
C194	CKXAV1H821EAG	CERAMIC 0.00082U K 50V		C334	CK1H104KGQBNG	CERAMIC 0.1U K 50V	
C194	CKXLB1H821YAG	CERAMIC 820P K 50V		C335	CXLB1C101VDN	ELECT 100U M 16V	
C194	CK1H821KGQBNG	CERAMIC 820P K 50V		C336	CXLB1E4R7VDN	ELECT 4.7U M 25V	
C195	CKXLB1H223YDG	CERAMIC 0.022U Z 50V		C336	CXLB1E4R7WAN	ELECT 4.7U M 25V	
C195	CK1H223ZGQFNG	CERAMIC 0.022U Z 50V		C337	CXLB1E4R7VDN	ELECT 4.7U M 25V	
C196	CK1H563KGABNG	CERAMIC 0.056U K 50V		C337	CXLB1E4R7WAN	ELECT 4.7U M 25V	
C198	CKXAV1H391EAG	CERAMIC 0.00039U K 50V		C339	CXLB1E4R7VDN	ELECT 4.7U M 25V	
C198	CKXLB1H391YAG	CERAMIC 390P K 50V		C339	CXLB1E4R7WAN	ELECT 4.7U M 25V	
C198	CK1H391KGQBNG	CERAMIC 390P K 50V		C340	CXLB1E4R7VDN	ELECT 4.7U M 25V	
C199	CKXLB1A105YDG	CERAMIC 1U Z 10V		C340	CXLB1E4R7WAN	ELECT 4.7U M 25V	
C199	CK1A105ZGQFNG	CERAMIC 1U Z 10V		C341	CXLB1E4R7VDN	ELECT 4.7U M 25V	
C199	CK1A105ZLZFN	CERAMIC 1U Z 10V		C341	CXLB1E4R7WAN	ELECT 4.7U M 25V	
C199	CK1A105ZMAFNG	CERAMIC 1U Z 10V		C342	CXLB1E4R7VDN	ELECT 4.7U M 25V	
C272	CPXLB1C100ZAN	NP-ELECT 10U M 16V		C342	CXLB1E4R7WAN	ELECT 4.7U M 25V	
C300	CXLB1E4R7VDN	ELECT 4.7U M 25V		C343	CXLB1E4R7VDN	ELECT 4.7U M 25V	
C300	CXLB1E4R7WAN	ELECT 4.7U M 25V		C343	CXLB1E4R7WAN	ELECT 4.7U M 25V	
C301	CXLB1E4R7VDN	ELECT 4.7U M 25V		C344	CXLB1E4R7VDN	ELECT 4.7U M 25V	
C301	CXLB1E4R7WAN	ELECT 4.7U M 25V		C344	CXLB1E4R7WAN	ELECT 4.7U M 25V	
C302	CXLB1E4R7VDN	ELECT 4.7U M 25V		C345	CKXLB1H272YAG	CERAMIC 2700P K 50V	
C302	CXLB1E4R7WAN	ELECT 4.7U M 25V		C346	CKXAV1C683EAG	CERAMIC 0.068U K 16V	
C303	CXLB1E4R7VDN	ELECT 4.7U M 25V		C346	CKXLB1C683YAG	CERAMIC 0.068U K 16V	
C303	CXLB1E4R7WAN	ELECT 4.7U M 25V		C346	CK1C683KGQBNG	CERAMIC 0.068U K 16V	
C304	CXLB1E4R7VDN	ELECT 4.7U M 25V		C359	CXLB1E4R7VDN	ELECT 4.7U M 25V	
C304	CXLB1E4R7WAN	ELECT 4.7U M 25V		C359	CXLB1E4R7WAN	ELECT 4.7U M 25V	
C305	CXLB1E4R7VDN	ELECT 4.7U M 25V		C400	CXLB1C101VDN	ELECT 100U M 16V	
C305	CXLB1E4R7WAN	ELECT 4.7U M 25V		C402	CKXAV1C104EAG	CERAMIC 0.1U K 16V	
C306	CXLB1E4R7VDN	ELECT 4.7U M 25V		C402	CKXLB1C104YAG	CERAMIC 0.1U K 16V	
C306	CXLB1E4R7WAN	ELECT 4.7U M 25V		C402	CK1C104KGQBNG	CERAMIC 0.1U K 16V	
C307	CXLB1E4R7VDN	ELECT 4.7U M 25V		C403	CXLB1C101VDN	ELECT 100U M 16V	
C307	CXLB1E4R7WAN	ELECT 4.7U M 25V		C405	CKXAV1C104EAG	CERAMIC 0.1U K 16V	
C308	CKXAV1H104EAG	CERAMIC 0.1U K 50V		C405	CKXLB1C104YAG	CERAMIC 0.1U K 16V	
C308	CKXLB1H104YAG	CERAMIC 0.1U K 50V		C405	CK1C104KGQBNG	CERAMIC 0.1U K 16V	
C308	CK1H104KGQBNG	CERAMIC 0.1U K 50V		C406	CXLB1C101VDN	ELECT 100U M 16V	
C309	CXLB1C101VDN	ELECT 100U M 16V		C408	CKXAV1C104EAG	CERAMIC 0.1U K 16V	
C310	CXLB1C101VDN	ELECT 100U M 16V		C408	CKXLB1C104YAG	CERAMIC 0.1U K 16V	
C311	CXLB1C101VDN	ELECT 100U M 16V		C408	CK1C104KGQBNG	CERAMIC 0.1U K 16V	
C312	CKXLB1E104YDG	CERAMIC 0.1U Z 25V		C409	CXLB1E220VDN	ELECT 22U M 25V	
C313	CXLB1C101VDN	ELECT 100U M 16V		C410	CXLB1C101VDN	ELECT 100U M 16V	
C317	CKXLB1H103YDG	CERAMIC 0.01U Z 50V		C411	CKXAV1H104EAG	CERAMIC 0.1U K 50V	
C320	CXLB1E4R7VDN	ELECT 4.7U M 25V		C411	CKXLB1E104YAG	CERAMIC 0.1U K 25V	
C320	CXLB1E4R7WAN	ELECT 4.7U M 25V		C411	CK1E104KGQBNG	CERAMIC 0.1U K 25V	
C321	CXLB1C1R0VDN	ELECT 1U M 16V		C412	CXLB0J470VDN	ELECT 47U M 6.3V	
C321	CXLB1C1R0WAN	ELECT 1U M 16V		C412	CXLB0J470WAN	ELECT 47U M 6.3V	
C322	CXLB1C1R0VDN	ELECT 1U M 16V		C413	CKXAV1H104EAG	CERAMIC 0.1U K 50V	
C322	CXLB1C1R0WAN	ELECT 1U M 16V		C413	CKXLB1E104YAG	CERAMIC 0.1U K 25V	
C323	CXLB1E4R7VDN	ELECT 4.7U M 25V		C413	CK1E104KGQBNG	CERAMIC 0.1U K 25V	
C323	CXLB1E4R7WAN	ELECT 4.7U M 25V		C506	CK1A105MLZBNG	CERAMIC 1U M 10V	
C324	CKXAV1C104EAG	CERAMIC 0.1U K 16V		C507	CK1A105MLZBNG	CERAMIC 1U M 10V	
C324	CKXLB1C104YAG	CERAMIC 0.1U K 16V		C602	CXLB1C471VDN	ELECT 470U M 16V	
C324	CK1C104KGQBNG	CERAMIC 0.1U K 16V		C603	CKXAV1C104EAG	CERAMIC 0.1U K 16V	
C325	CKXAV1C104EAG	CERAMIC 0.1U K 16V		C603	CKXLB1C104YAG	CERAMIC 0.1U K 16V	
C325	CKXLB1C104YAG	CERAMIC 0.1U K 16V		C603	CK1C104KGQBNG	CERAMIC 0.1U K 16V	
C325	CK1C104KGQBNG	CERAMIC 0.1U K 16V		C604	CKXAV1H272EAG	CERAMIC 0.0027U K 50V	
C326	CXLB1C1R0VDN	ELECT 1U M 16V		C604	CKXLB1H272YAG	CERAMIC 2700P K 50V	
C326	CXLB1C1R0WAN	ELECT 1U M 16V		C606	CKXAV1H562EAG	CERAMIC 0.0056U K 50V	
C327	CKXAV1C104EAG	CERAMIC 0.1U K 16V		C606	CKXLB1H562YAG	CERAMIC 5600P K 50V	
C327	CKXLB1C104YAG	CERAMIC 0.1U K 16V		D400	DD1SS355----G	DIODE 1SS355-TE-17	
C327	CK1C104KGQBNG	CERAMIC 0.1U K 16V		D401	DD1SS355----G	DIODE 1SS355-TE-17	

Ref. No.	Part No.	Description	Safety	Ref. No.	Part No.	Description	Safety
D402	DD1SS355----G	DIODE 1SS355-TE-17		R163	RGF3302JTCANL	MT-GLAZE 33K JA 1/10W	
D405	DD1SS355----G	DIODE 1SS355-TE-17		R188	RGF3901JTCANL	MT-GLAZE 3.9K JA 1/10W	
D408	DD1SS355----G	DIODE 1SS355-TE-17		R189	RGF8200JTCANL	MT-GLAZE 820 JA 1/10W	
D600	DD1SS355----G	DIODE 1SS355-TE-17		R191	RGF1001JTCANL	MT-GLAZE 1K JA 1/10W	
IC003	QLA7217M-T--G	IC LA7217M-T-TRM		R192	RGF5601JTCANL	MT-GLAZE 5.6K JA 1/10W	
IC301	QLV1116NV-E-P	IC LV1116NV-TLM-E		R193	RGF4704JTCANL	MT-GLAZE 4.7M JA 1/10W	
IC400	QL88M05TL---P	IC L88M05TL-TL		R194	RGF1503JTCANL	MT-GLAZE 150K JA 1/10W	
IC401	QBA09FP----P	IC BA09FP-E2		R196	RGF4702JTCANL	MT-GLAZE 47K JA 1/10W	
IC402	QTC4052BF---P	IC TC4052BF(EL)		R197	RGF3302JTCANL	MT-GLAZE 33K JA 1/10W	
J111	RGFR000ZTCANL	MT-GLAZE 0.000 ZA 1/10W		R198	RGF1001JTCANL	MT-GLAZE 1K JA 1/10W	
J313	RGFR000ZTCANL	MT-GLAZE 0.000 ZA 1/10W		R199	RGF1001JTCANL	MT-GLAZE 1K JA 1/10W	
J319	RGFR000ZTCANL	MT-GLAZE 0.000 ZA 1/10W		R250	RGKR000ZTFANL	MT-GLAZE 0.000 ZA 1/3W	
J340	RGFR000ZTCANL	MT-GLAZE 0.000 ZA 1/10W		R251	RGKR000ZTFANL	MT-GLAZE 0.000 ZA 1/3W	
J609	RGFR000ZTCANL	MT-GLAZE 0.000 ZA 1/10W		R276	RGFR000ZTCANL	MT-GLAZE 0.000 ZA 1/10W	
J610	RGFR000ZTCANL	MT-GLAZE 0.000 ZA 1/10W		R279	RGF1002JTCANL	MT-GLAZE 10K JA 1/10W	
J83	RGFR000ZTCANL	MT-GLAZE 0.000 ZA 1/10W		R280	RGF1002JTCANL	MT-GLAZE 10K JA 1/10W	
K500	1LB4J12B06002	JACK,RCA-6		R281	RGF4700JTCANL	MT-GLAZE 470 JA 1/10W	
K502	1AV4J12B07600	JACK,PHONE D3.6		R282	RGF68R0JTCANL	MT-GLAZE 68 JA 1/10W	
K502	1LB4J12B08000	JACK,PHONE D3.6		R301	RGFR000ZTCANL	MT-GLAZE 0.000 ZA 1/10W	
K502	1LB4J12B09200	JACK,PHONE D3.6		R303	RGFR000ZTCANL	MT-GLAZE 0.000 ZA 1/10W	
L199	1AV4L2GM3R3MG	INDUCTOR,3.3U M		R307	RGFR000ZTCANL	MT-GLAZE 0.000 ZA 1/10W	
L201	RGER000ZTBANL	MT-GLAZE 0.000 ZA 1/8W		R309	RGF4702JTCANL	MT-GLAZE 47K JA 1/10W	
L202	RGER000ZTBANL	MT-GLAZE 0.000 ZA 1/8W		R310	RGF1000JTCANL	MT-GLAZE 100 JA 1/10W	
L203	RGER000ZTBANL	MT-GLAZE 0.000 ZA 1/8W		R311	RGF4702JTCANL	MT-GLAZE 47K JA 1/10W	
L211	1AV4L2GM3R3MG	INDUCTOR,3.3U M		R312	RGF1000JTCANL	MT-GLAZE 100 JA 1/10W	
L214	1AV4L2GM3R3MG	INDUCTOR,3.3U M		R318	RGFR000ZTCANL	MT-GLAZE 0.000 ZA 1/10W	
L300	1AV4L2GM3R3MG	INDUCTOR,3.3U M		R319	RGF1102JTCANL	MT-GLAZE 11K JA 1/10W	
L302	1AV4L2GM3R3MG	INDUCTOR,3.3U M		R320	RGF1102JTCANL	MT-GLAZE 11K JA 1/10W	
L303	1AV4L2GM3R3MG	INDUCTOR,3.3U M		R321	RGF3901JTCANL	MT-GLAZE 3.9K JA 1/10W	
L500	RGER000ZTBANL	MT-GLAZE 0.000 ZA 1/8W		R322	RGFR000ZTCANL	MT-GLAZE 0.000 ZA 1/10W	
L501	RGER000ZTBANL	MT-GLAZE 0.000 ZA 1/8W		R324	RGF1102JTCANL	MT-GLAZE 11K JA 1/10W	
PB100	1LG4B10Y0150A	PWB SUB N5AV		R325	RGF3901JTCANL	MT-GLAZE 3.9K JA 1/10W	
PB100	1LG4B10Y01500	PWB SUB-COMP N5AV		R326	RGF3901JTCANL	MT-GLAZE 3.9K JA 1/10W	
Q198	7T200220	TR 2SC2412K(P)-6		R327	RGF1102JTCANL	MT-GLAZE 11K JA 1/10W	
Q199	7T200220	TR 2SC2412K(P)-6		R328	RGF3901JTCANL	MT-GLAZE 3.9K JA 1/10W	
Q201	7T200220	TR 2SC2412K(P)-6		R329	RGF1201JTCANL	MT-GLAZE 1.2K JA 1/10W	
Q202	7T200221	TR 2SA1037K(P)-4		R330	RGFR000ZTCANL	MT-GLAZE 0.000 ZA 1/10W	
Q203	7T200220	TR 2SC2412K(P)-6		R335	RGF1201JTCANL	MT-GLAZE 1.2K JA 1/10W	
Q204	7T200220	TR 2SC2412K(P)-6		R336	RGFR000ZTCANL	MT-GLAZE 0.000 ZA 1/10W	
Q205	7T200220	TR 2SC2412K(P)-6		R349	RGF3601JTCANL	MT-GLAZE 3.6K JA 1/10W	
Q300	7T200220	TR 2SC2412K(P)-6		R350	RGF3601JTCANL	MT-GLAZE 3.6K JA 1/10W	
Q301	7T200220	TR 2SC2412K(P)-6		R351	RGF5601JTCANL	MT-GLAZE 5.6K JA 1/10W	
Q307	7T200220	TR 2SC2412K(P)-6		R352	RGF5601JTCANL	MT-GLAZE 5.6K JA 1/10W	
Q308	7T200220	TR 2SC2412K(P)-6		R353	RGF6802JTCANL	MT-GLAZE 68K JA 1/10W	
Q600	TTPC8109----P	TR TPC8109		R354	RGF5601JTCANL	MT-GLAZE 5.6K JA 1/10W	
Q601	7T200220	TR 2SC2412K(P)-6		R355	RGF6802JTCANL	MT-GLAZE 68K JA 1/10W	
R101	RGF1000JTCANL	MT-GLAZE 100 JA 1/10W		R360	RGF1201JTCANL	MT-GLAZE 1.2K JA 1/10W	
R102	RGF1000JTCANL	MT-GLAZE 100 JA 1/10W		R361	RGF1201JTCANL	MT-GLAZE 1.2K JA 1/10W	
R103	RGF1000JTCANL	MT-GLAZE 100 JA 1/10W		R362	RGF1503JTCANL	MT-GLAZE 150K JA 1/10W	
R104	RGF1000JTCANL	MT-GLAZE 100 JA 1/10W		R363	RGF5602JTCANL	MT-GLAZE 56K JA 1/10W	
R107	RGF2202JTCANL	MT-GLAZE 22K JA 1/10W		R364	RGF1503JTCANL	MT-GLAZE 150K JA 1/10W	
R113	RGKR000ZTFANL	MT-GLAZE 0.000 ZA 1/3W		R365	RGF5602JTCANL	MT-GLAZE 56K JA 1/10W	
R114	RGKR000ZTFANL	MT-GLAZE 0.000 ZA 1/3W		R366	RGFR000ZTCANL	MT-GLAZE 0.000 ZA 1/10W	
R115	RGFR000ZTCANL	MT-GLAZE 0.000 ZA 1/10W		R367	RGFR000ZTCANL	MT-GLAZE 0.000 ZA 1/10W	
R116	RGFR000ZTCANL	MT-GLAZE 0.000 ZA 1/10W		R380	RGF2201JTCANL	MT-GLAZE 2.2K JA 1/10W	
R130	RGKR000ZTFANL	MT-GLAZE 0.000 ZA 1/3W		R381	RGF2201JTCANL	MT-GLAZE 2.2K JA 1/10W	
R131	RGKR000ZTFANL	MT-GLAZE 0.000 ZA 1/3W		R404	RGFR000ZTCANL	MT-GLAZE 0.000 ZA 1/10W	
R135	RGKR000ZTFANL	MT-GLAZE 0.000 ZA 1/3W		R407	RSXLB1150JXAS	OXIDE-MT 15 JA 1W	
R150	RGF47R0JTCANL	MT-GLAZE 47 JA 1/10W		R407	RSXLB1150JYBS	OXIDE-MT 15JA 1W	
R151	RGF6802JTCANL	MT-GLAZE 68K JA 1/10W		R407	RS115R0JGCAEN	OXIDE-MT 15 JA 1W	
R152	RGF3302JTCANL	MT-GLAZE 33K JA 1/10W		R407	RS115R0JGCANN	OXIDE-MT 15 JA 1W	
R153	RGF1001JTCANL	MT-GLAZE 1K JA 1/10W		R408	RG133R0JTEANL	MT-GLAZE 33 JA 1W	
R154	RDD47R0JPAANN	CARBON 47 JA 1/6W		R409	RGAR000ZTDANL	MT-GLAZE 0.000 ZA 1/2W	
R155	RGF6802JTCANL	MT-GLAZE 68K JA 1/10W		R500	RGF1003JTCANL	MT-GLAZE 100K JA 1/10W	
R158	RGF1500JTCANL	MT-GLAZE 150 JA 1/10W		R501	RGFR000ZTCANL	MT-GLAZE 0.000 ZA 1/10W	
R159	RGF1500JTCANL	MT-GLAZE 150 JA 1/10W		R502	RGF1003JTCANL	MT-GLAZE 100K JA 1/10W	
R160	RGF1001JTCANL	MT-GLAZE 1K JA 1/10W		R504	RGF1003JTCANL	MT-GLAZE 100K JA 1/10W	
R161	RGF3300JTCANL	MT-GLAZE 330 JA 1/10W		R505	RGFR000ZTCANL	MT-GLAZE 0.000 ZA 1/10W	
R162	RGF3300JTCANL	MT-GLAZE 330 JA 1/10W		R506	RGF1003JTCANL	MT-GLAZE 100K JA 1/10W	

Ref. No.	Part No.	Description	Safety	Ref. No.	Part No.	Description	Safety
R507	RGFR000ZTCANL	MT-GLAZE 0.000 ZA 1/10W		SW1952	1LB4S10B0200J	SWITCH,PUSH 1P-1TX1	
R508	RGF1003JTCANL	MT-GLAZE 100K JA 1/10W		SW1953	1AV4S10B0900J	SWITCH,PUSH 1P-1T	
R509	RGFR000ZTCANL	MT-GLAZE 0.000 ZA 1/10W		SW1953	1LB4S10B0200J	SWITCH,PUSH 1P-1TX1	
R510	RGF1003JTCANL	MT-GLAZE 100K JA 1/10W		SW1954	1AV4S10B0900J	SWITCH,PUSH 1P-1T	
R511	RGFR000ZTCANL	MT-GLAZE 0.000 ZA 1/10W		SW1954	1LB4S10B0200J	SWITCH,PUSH 1P-1TX1	
R514	RGFR000ZTCANL	MT-GLAZE 0.000 ZA 1/10W		SW1955	1AV4S10B0900J	SWITCH,PUSH 1P-1T	
R515	RGFR000ZTCANL	MT-GLAZE 0.000 ZA 1/10W		SW1955	1LB4S10B0200J	SWITCH,PUSH 1P-1TX1	
R516	RGF4703JTCANL	MT-GLAZE 470K JA 1/10W		SW1956	1AV4S10B0900J	SWITCH,PUSH 1P-1T	
R517	RGK10R0JTFANL	MT-GLAZE 10 JA 1/3W		SW1956	1LB4S10B0200J	SWITCH,PUSH 1P-1TX1	
R518	RGFR000ZTCANL	MT-GLAZE 0.000 ZA 1/10W		U1901	1AV4U20C11701	UNIT,REMOCON RECEIVER	
R519	RGF4703JTCANL	MT-GLAZE 470K JA 1/10W		A3000	1LG0B10Y02000	ASSY POWER-COMP N5AV	
R520	RGK10R0JTFANL	MT-GLAZE 10 JA 1/3W		A600	1LG0B10Y0200A	ASSY POWER N5AV	
R521	RGFR000ZTCANL	MT-GLAZE 0.000 ZA 1/10W		C6001	CK3A102KANHNN	CERAMIC 1000P K 1K	
R600	RGKR000ZTFANL	MT-GLAZE 0.000 ZA 1/3W		C6001	CK3A102KCRDNN	CERAMIC 1000P K 1K	
R602	RGF1002JTCANL	MT-GLAZE 10K JA 1/10W		C6001	CK3A102KCTBNN	CERAMIC 1000P K 1K	
R604	RDD4701JPAANN	CARBON 4.7K JA 1/6W		C6002	CE1E222M5DANN	ELECT 2200U M 25V	
R604	RDXLBD472JVAN	CARBON 4.7K JA 1/6W		C6003	CEXLB1C102VDN	ELECT 1000U M 16V	
R605	RGF6801JTCANL	MT-GLAZE 6.8K JA 1/10W		C6004	CEXLB1A471VDN	ELECT 470U M 10V	
X199	1AV4V11B0350N	OSC,CERAMIC 500.0KHZ		C6005	CKXAV1H103EAG	CERAMIC 0.01U K 50V	
A002	1LG0B10Y0190B	ASSY KEY+RC N5AV		C6005	CKXLB1H103YAG	CERAMIC 0.01U K 50V	
C1901	CKXAV1H102EAG	CERAMIC 1000P K 50V		C6006	CEXLB1H4R7VEN	ELECT 4.7U M 50V	
C1901	CKXLB1H102YAG	CERAMIC 1000P K 50V		C6007	CK1H104KLZBNG	CERAMIC 0.1U K 50V	
C1901	CK1H102KGQBNG	CERAMIC 1000P K 50V		C601	CMXLB27224XAN	MT-POLYPRO 0.22U M 275V	⚠
C1902	CK0J106KMBBNG	CERAMIC 10U K 6.3V		C6010	CK3A102KANHNN	CERAMIC 1000P K 1K	
C1903	CK0J106KMBBNG	CERAMIC 10U K 6.3V		C6010	CK3A102KCRDNN	CERAMIC 1000P K 1K	
C1905	CKXLB1H104YDG	CERAMIC 0.1U Z 50V		C6010	CK3A102KCTBNN	CERAMIC 1000P K 1K	
C1905	CK1E104ZGQFNG	CERAMIC 0.1U Z 25V		C6011	CK3A102KANHNN	CERAMIC 1000P K 1K	
D1901	DLXLBB011---N	LED BT-102YXN-31		C6011	CK3A102KCRDNN	CERAMIC 1000P K 1K	
D1901A	1LB2SAM0001--	LED SPACER-N3EA		C6011	CK3A102KCTBNN	CERAMIC 1000P K 1K	
D1902	DLSPR-39MVWFN	LED SPR-39MVWF		C6012	CEXLB1E222VDN	ELECT 2200U M 25V	
D1902A	1LB2SAM0001--	LED SPACER-N3EA		C6014	CEXLB1C102VDN	ELECT 1000U M 16V	
L1955	1AV4L26B0130G	INDUCTOR,600 OHM		C6015	CKXAV1H103EAG	CERAMIC 0.01U K 50V	
PB1900	1LG4B10Y0150B	PWB,KEY+RC N5AV		C6015	CKXLB1H103YAG	CERAMIC 0.01U K 50V	
PB1900	1LG4B10Y01500	PWB SUB-COMP N5AV		C6016	CK3A102KANHNN	CERAMIC 1000P K 1K	
Q1901	7T200220	TR 2SC2412K(P)-6		C6016	CK3A102KCRDNN	CERAMIC 1000P K 1K	
Q1902	7T200220	TR 2SC2412K(P)-6		C6016	CK3A102KCTBNN	CERAMIC 1000P K 1K	
R1901	RGF1000JTCANL	MT-GLAZE 100 JA 1/10W		C6017	CK3A102KANHNN	CERAMIC 1000P K 1K	
R1902	RGF2200JTCANL	MT-GLAZE 220 JA 1/10W		C6017	CK3A102KCRDNN	CERAMIC 1000P K 1K	
R1903	RGF2200JTCANL	MT-GLAZE 220 JA 1/10W		C6017	CK3A102KCTBNN	CERAMIC 1000P K 1K	
R1904	RGFR000ZTCANL	MT-GLAZE 0.000 ZA 1/10W		C6018	CEXLB1V102VDN	ELECT 1000U M 35V	
R1906	RGFR000ZTCANL	MT-GLAZE 0.000 ZA 1/10W		C6019	CEXLB1V102VDN	ELECT 1000U M 35V	
R1909	RGF2202JTCANL	MT-GLAZE 22K JA 1/10W		C602	CKXAA2E471AHN	CERAMIC 470P K 250V	⚠
R1910	RGF2202JTCANL	MT-GLAZE 22K JA 1/10W		C602	CKXLB2G471ZHN	CERAMIC 470P K 400V	⚠
R1911	RGF2700JTCANL	MT-GLAZE 270 JA 1/10W		C6020	CEXLB1V222WAN	ELECT 2200U M 35V	
R1912	RGF2700JTCANL	MT-GLAZE 270 JA 1/10W		C6021	CKXAV1H103EAG	CERAMIC 0.01U K 50V	
R1919	RGF4701JTCANL	MT-GLAZE 4.7K JA 1/10W		C6021	CKXLB1H103YAG	CERAMIC 0.01U K 50V	
R1951	RGF3302FTCANL	MT-GLAZE 33K FA 1/10W		C6024	CKXAV1C224EAG	CERAMIC 0.22U K 16V	
R1951	RGG3302FTCANL	MT-GLAZE 33K FA 1/16W		C6024	CK1C224KGQBNG	CERAMIC 0.22U K 16V	
R1952	RGF1502FTCANL	MT-GLAZE 15K FA 1/10W		C6024	CK1C224KLZBNG	CERAMIC 0.22U K 16V	
R1952	RGG1502FTCANL	MT-GLAZE 15K FA 1/16W		C6026	CKXLB1C105YAG	CERAMIC 1U K 16V	
R1953	RGF1002FTCANL	MT-GLAZE 10K FA 1/10W		C6027	CKXLB1C105YAG	CERAMIC 1U K 16V	
R1953	RGG1002FTCANL	MT-GLAZE 10K FA 1/16W		C6028	CKXLB1C105YAG	CERAMIC 1U K 16V	
R1954	RGF5601FTCANL	MT-GLAZE 5.6K FA 1/10W		C6029	CKXAV1H104EAG	CERAMIC 0.1U K 50V	
R1954	RGG5601FTCANL	MT-GLAZE 5.6K FA 1/16W		C6029	CKXLB1H104YAG	CERAMIC 0.1U K 50V	
R1955	RGF4701FTCANL	MT-GLAZE 4.7K FA 1/10W		C603	CKXAA2E471AHN	CERAMIC 470P K 250V	⚠
R1955	RGG4701FTCANL	MT-GLAZE 4.7K FA 1/16W		C603	CKXLB2G471ZHN	CERAMIC 470P K 400V	⚠
R1956	RGF4701FTCANL	MT-GLAZE 4.7K FA 1/10W		C6030	CK1H104KLZBNG	CERAMIC 0.1U K 50V	
R1956	RGG4701FTCANL	MT-GLAZE 4.7K FA 1/16W		C6031	CK1H104KLZBNG	CERAMIC 0.1U K 50V	
R1957	RGF1002FTCANL	MT-GLAZE 10K FA 1/10W		C6032	CEXLB1H220VEN	ELECT 22U M 50V	
R1957	RGG1002FTCANL	MT-GLAZE 10K FA 1/16W		C6033	CG2W104KFDAAN	MT-POLYEST 0.1U K 450V	
SC1901	1AV4Z30B0220G	SURGE-ABSORBER		C605	CMXLB27224XAN	MT-POLYPRO 0.22U M 275V	⚠
SC1902	1AV4Z30B0220G	SURGE-ABSORBER		C609	CKXAA2E101AHN	CERAMIC 100P K 250V	⚠
SC1903	1AV4Z30B0220G	SURGE-ABSORBER		C610	CKXAA2E101AHN	CERAMIC 100P K 250V	⚠
SC1956	1AV4Z30B0220G	SURGE-ABSORBER		C611	CKXAV1H103EAG	CERAMIC 0.01U K 50V	
SW1950	1AV4S10B0900J	SWITCH,PUSH 1P-1T		C611	CKXLB1H103YAG	CERAMIC 0.01U K 50V	
SW1950	1LB4S10B0200J	SWITCH,PUSH 1P-1TX1		C612	CK1H474ZGBFNG	CERAMIC 0.47U Z 50V	
SW1951	1AV4S10B0900J	SWITCH,PUSH 1P-1T		C613	CKXLB1H472YAG	CERAMIC 4700P K 50V	
SW1951	1LB4S10B0200J	SWITCH,PUSH 1P-1TX1		C614	CKXAV1H104EAG	CERAMIC 0.1U K 50V	
SW1952	1AV4S10B0900J	SWITCH,PUSH 1P-1T		C614	CKXLB1H104YAG	CERAMIC 0.1U K 50V	

Ref. No.	Part No.	Description	Safety	Ref. No.	Part No.	Description	Safety
C615	CEXLB1V470VEN	ELECT 47U M 35V		D616	DDXLBB042---G	DIODE LL4148	
C616	CKXAV1H104EAG	CERAMIC0.1U K 50V		D618	DDXLBB042---G	DIODE LL4148	
C616	CKXLB1H104YAG	CERAMIC 0.1U K 50V		D620	DDXLBB042---G	DIODE LL4148	
C617	CEXLB1E470VEN	ELECT 47U M 25V		D621	DDXLBB042---G	DIODE LL4148	
C618	CG2G105JAPANN	MT-POLYEST 1U J 400V		D622	DDXLBB042---G	DIODE LL4148	
C618	CG2G105KFBACN	MT-POLYEST 1U K 400V		D623	DDXLBB042---G	DIODE LL4148	
C619	CKXLB3D222ZBN	CERAMIC 2200P K 2K		D624	DDXLBB041---N	DIODE EU1	
C619	CK3D222KANHNN	CERAMIC 2200P K 2K		D625	DDXLBB042---G	DIODE LL4148	
C620	CK1H474ZGBFNG	CERAMIC 0.47U Z 50V		D626	DDXLBB042---G	DIODE LL4148	
C621	CK1H103KLZBNG	CERAMIC 0.01U K 50V		D638	DZXLBZA16A--N	ZENER DIODE MTZJ16A	
C622	CK1H103KLZBNG	CERAMIC 0.01U K 50V		D650	DCPC123X5YFZN	PHOTO COUPLE PC123X5YFZ0F	⚠
C623	CK1C225ZGAFNG	CERAMIC 2.2U Z 16V		D650	DCPC123Y52--N	PHOTO COUPLE PC123Y52J00F	⚠
C624	CKXAV1H104EAG	CERAMIC0.1U K 50V		D651	DCPC123X5YFZN	PHOTO COUPLE PC123X5YFZ0F	⚠
C624	CKXLB1H104YAG	CERAMIC 0.1U K 50V		D651	DCPC123Y52--N	PHOTO COUPLE PC123Y52J00F	⚠
C625	CG2W104KFDAAN	MT-POLYEST 0.1U K 450V		D652	DCPC123X5YFZN	PHOTO COUPLE PC123X5YFZ0F	⚠
C626	CG2W104KFDAAN	MT-POLYEST 0.1U K 450V		D652	DCPC123Y52--N	PHOTO COUPLE PC123Y52J00F	⚠
C628	CKXAV1H224EAG	CERAMIC 0.22U K 50V		D661	DDRB215T-90-N	DIODE RB215T-90	
C628	CKXLB1H224YAG	CERAMIC 0.22U K 50V		D661B	ZAV6120KE24--	G-FLOIL GREASE*SY-600	
C629	CKXLB1H224YAG	CERAMIC 0.22U K 50V		D663	DDRB085T-60-N	DIODE RB085T-60	
C630	CKXLB1H471YAG	CERAMIC 470P K 50V		D663B	ZAV6120KE24--	G-FLOIL GREASE*SY-600	
C631	CKXLB1H152YAG	CERAMIC 1500P K 50V		D665	DDYG862C10MYN	DIODE YG862C10R-MY	
C632	CKXLB1H104YAG	CERAMIC 0.1U K 50V		D665B	ZAV6120KE24--	G-FLOIL GREASE*SY-600	
C633	CKXLB1H102YAG	CERAMIC 1000P K 50V		F601	FFXLBB003VC-N	FUSE 250V 5A	
C634	CKXLB1H102YAG	CERAMIC 1000P K 50V		IC601	QVIPER53EDIPN	IC VIPER53DIP-E	
C635	CKXLB3D471YHN	CERAMIC 470P K 2K		IC601B	ZAV6120KE24--	G-FLOIL GREASE*SY-600	
C635	CKXLB3D471ZBN	CERAMIC 470P K 2K		IC602	QL6563TR----P	IC L6563TR	⚠
C635	CK3D471KANHNN	CERAMIC 470P K 2K		IC603	QL6599DTR---P	IC L6599DTR	
C635	CK3D471KCTBNN	CERAMIC 470P K 2K		IC604	QUPC1093J---N	IC UPC1093J	
C636	CMXAV2K473ACM	MT-POLYPRO 0.047U H 800V		IC608	QXXAVC950---P	IC LM393D	
C636	CMXLB2K473YCN	MT-POLYPRO 0.047U J 800V		IC610	QUPC1093J---N	IC UPC1093J	
C637	CKXLB1H104YAG	CERAMIC 0.1U K 50V		JP607	RGFR000ZTCANL	MT-GLAZE 0.000 ZA 1/10W	
C638	CEXLB1E470VEN	ELECT 47U M 25V		JP608	RGFR000ZTCANL	MT-GLAZE 0.000 ZA 1/10W	
C639	CFXLB2A104YAN	POLYESTER 0.1U J 100V		JP611	RGFR000ZTCANL	MT-GLAZE 0.000 ZA 1/10W	
C639	CH2A104JAHANN	MT-COMPO 0.1U J 100V		JP612	RGFR000ZTCANL	MT-GLAZE 0.000 ZA 1/10W	
C640	CEXLB1V470VEN	ELECT 47U M 35V		L601	1LB4L26B0970N	INDUCTOR,200UH	
C641	CKXLB1H104YAG	CERAMIC 0.1U K 50V		L602	1LB4F35B0250N	LINE FILTER	
C643	CCXAV1H101ABG	CERAMIC0.0001U J 50.0V		L606	1LB4L26B0980N	INDUCTOR,0.8UH	
C643	CCXLB1H101ZBG	CERAMIC 100P J 50V		L607	1LB4L26B0980N	INDUCTOR,0.8UH	
C643	CC1H101JGQCNG	CERAMIC 100P J 50V		L608	1LB4L26B0960N	INDUCTOR,3.0UH	⚠
C647	CEXAV2W151CJN	ELECT 150U M 450V		PB600	1LG4B10Y0170A	PWB,POWER N5AV	
C647	CEXLB2W151UFN	ELECT 150U M 450V		PB600	1LG4B10Y01700	PWB,POWER N5AV+KEY(N5CV)	
C648	CG2G104KAPANN	MT-POLYEST 0.1U K 400V		Q601	TSTP20NM50FPN	TR STP20NM50FP-SA1	
C649	CKXLB1H103YAG	CERAMIC 0.01U K 50V		Q601B	ZAV6120KE24--	G-FLOIL GREASE*SY-600	
C652	CKXAA2E102AHN	CERAMIC 1000P K 250V	⚠	Q602	T2SK3505-FMYN	TR 2SK3505-01MR-MY	
C652	CKXLB2G102ZJN	CERAMIC 1000P M 400V	⚠	Q602B	ZAV6120KE24--	G-FLOIL GREASE*SY-600	
C653	CKXAA2E471AHN	CERAMIC 470P K 250V	⚠	Q603	T2SK3505-FMYN	TR 2SK3505-01MR-MY	
C653	CKXLB2G471ZHN	CERAMIC 470P K 400V	⚠	Q603B	ZAV6120KE24--	G-FLOIL GREASE*SY-600	
C655	CKXLB3D471YHN	CERAMIC 470P K 2K		Q606	T2SC3332-S--C	TR 2SC3332-S-AA	
C655	CKXLB3D471ZBN	CERAMIC 470P K 2K		Q607	7T200220	TR 2SC2412K(P)-6	
C655	CK3D471KANHNN	CERAMIC 470P K 2K		Q608	7T200220	TR 2SC2412K(P)-6	
C655	CK3D471KCRDNN	CERAMIC 470P K 2K		Q609	7T200221	TR 2SA1037K(P)-4	
C655	CK3D471KCTBNN	CERAMIC 470P K 2K		Q610	7T200221	TR 2SA1037K(P)-4	
D601	DDFMD-G26S--N	DIODE FMD-G26S		Q611	7T200220	TR 2SC2412K(P)-6	
D601B	ZAV6120KE24--	G-FLOIL GREASE*SY-600		Q612	T2SA984-F---N	TR 2SA984-F	
D602	DDXLBB048---N	DIODE RL255		Q613	7T200220	TR 2SC2412K(P)-6	
D603	DDXLBB064---N	DIODE D10SB60		R6000	RGF4700FTCANL	MT-GLAZE 470 FA 1/10W	
D603B	ZAV6120KE24--	G-FLOIL GREASE*SY-600		R6001	RGF4701FTCANL	MT-GLAZE 4.7K FA 1/10W	
D604	DDXLBB041---N	DIODE EU1		R6002	RGF47R0JTANL	MT-GLAZE 47 JA 1/10W	
D605	DZXLBZA16A--N	ZENER DIODE MTZJ16A		R6003	RGF1002FTCANL	MT-GLAZE 10K FA 1/10W	
D606	DDXLBB041---N	DIODE EU1		R6005	RGF5600FTCANL	MT-GLAZE 560 FA 1/10W	
D607	DDXLBB035---N	DIODE EG01C		R6006	RGF68R0JTANL	MT-GLAZE 68 JA 1/10W	
D608	DDXLBB042---G	DIODE LL4148		R6007	RGFR000ZTCANL	MT-GLAZE 0.000 ZA 1/10W	
D610	DDXLBB042---G	DIODE LL4148		R6008	RGF2201JTANL	MT-GLAZE 2.2K JA 1/10W	
D611	DDXLBB042---G	DIODE LL4148					
D612	DDXLBB042---G	DIODE LL4148					
D613	DDXLBB042---G	DIODE LL4148					
D615	DDXLBB042---G	DIODE LL4148					

Ref. No.	Part No.	Description	Safety	Ref. No.	Part No.	Description	Safety
R6009	RGF2201JTCANL	MT-GLAZE 2.2K JA 1/10W		R625	RGB7503JTBANL	MT-GLAZE 750K JA 1/4W	
R6012	RG13301JTEANL	MT-GLAZE 3.3K JA 1W		R626	RGB3903JTBANL	MT-GLAZE 390K JA 1/4W	
R6013	RGA1501JTDANL	MT-GLAZE 1.5K JA 1/2W		R627	RGF1002JTCANL	MT-GLAZE 10K JA 1/10W	
R6015	RGF4700JTCANL	MT-GLAZE 470 JA 1/10W		R629	RGF4702JTCANL	MT-GLAZE 47K JA 1/10W	
R6017	RGA1001JTDANL	MT-GLAZE 1K JA 1/2W		R630	RGFR000ZTCANL	MT-GLAZE 0.000 ZA 1/10W	
R6018	RGF1001JTCANL	MT-GLAZE 1K JA 1/10W		R631	RGB10R0JTBANL	MT-GLAZE 10 JA 1/4W	
R6019	RGF2201JTCANL	MT-GLAZE 2.2K JA 1/10W		R632	RGB10R0JTBANL	MT-GLAZE 10 JA 1/4W	
R602	RGA4703FTDANL	MT-GLAZE 470K FA 1/2W		R633	RSXLB2R33JXAS	OXIDE-MT 0.33 JA 2W	
R602	RGA4703JTDANL	MT-GLAZE 470K JA 1/2W		R633	RSXLB2R33JYBS	OXIDE-MT 0.33 JA 2W	
R6020	RGF8201FTCANL	MT-GLAZE 8.2K FA 1/10W		R633	RS2R330JGDAGN	OXIDE-MT 0.33 JA 2W	
R6021	RGF1501FTCANL	MT-GLAZE 1.5K FA 1/10W		R633	RS2R330JGDANN	OXIDE-MT 0.33 JA 2W	
R6022	RGF1002FTCANL	MT-GLAZE 10K FA 1/10W		R634	RSXLB2R33JXAS	OXIDE-MT 0.33 JA 2W	
R6023	RGF4700JTCANL	MT-GLAZE 470 JA 1/10W		R634	RSXLB2R33JYBS	OXIDE-MT 0.33 JA 2W	
R6024	RGF2702JTCANL	MT-GLAZE 27K JA 1/10W		R634	RS2R330JGDAGN	OXIDE-MT 0.33 JA 2W	
R6025	RGF4701JTCANL	MT-GLAZE 4.7K JA 1/10W		R634	RS2R330JGDANN	OXIDE-MT 0.33 JA 2W	
R6026	RGF1002JTCANL	MT-GLAZE 10K JA 1/10W		R635	RGB1001JTBANL	MT-GLAZE 1K JA 1/4W	
R6027	RGF1001JTCANL	MT-GLAZE 1K JA 1/10W		R636	RGF4702JTCANL	MT-GLAZE 47K JA 1/10W	
R6028	RGF1001JTCANL	MT-GLAZE 1K JA 1/10W		R637	RG11202JTEANL	MT-GLAZE 12K JA 1W	
R6029	RGF5603JTCANL	MT-GLAZE 560K JA 1/10W		R642	RGF1002JTCANL	MT-GLAZE 10K JA 1/10W	
R603	DHXAVB019---N	THERMISTOR NTPAD5R1LDNB0 		R643	RGF1502JTCANL	MT-GLAZE 15K JA 1/10W	
R6030	RGFR000ZTCANL	MT-GLAZE 0.000 ZA 1/10W		R644	RGF3303JTCANL	MT-GLAZE 330K JA 1/10W	
R6031	RGF1002JTCANL	MT-GLAZE 10K JA 1/10W		R645	RGF2001JTCANL	MT-GLAZE 2K JA 1/10W	
R6032	RGF1001JTCANL	MT-GLAZE 1K JA 1/10W		R646	RGF4701FTCANL	MT-GLAZE 4.7K FA 1/10W	
R6033	RGF1802JTCANL	MT-GLAZE 18K JA 1/10W		R647	RGF1002JTCANL	MT-GLAZE 10K JA 1/10W	
R6034	RGF4702JTCANL	MT-GLAZE 47K JA 1/10W		R648	RGF4702JTCANL	MT-GLAZE 47K JA 1/10W	
R6035	RGF3301JTCANL	MT-GLAZE 3.3K JA 1/10W		R649	RGB10R0JTBANL	MT-GLAZE 10 JA 1/4W	
R6036	RGF1003JTCANL	MT-GLAZE 100K JA 1/10W		R650	RGB10R0JTBANL	MT-GLAZE 10 JA 1/4W	
R6037	RGF4702JTCANL	MT-GLAZE 47K JA 1/10W		R651	RGF4702JTCANL	MT-GLAZE 47K JA 1/10W	
R6038	RGF5601JTCANL	MT-GLAZE 5.6K JA 1/10W		R652	RGB10R0JTBANL	MT-GLAZE 10 JA 1/4W	
R6039	RGF4701JTCANL	MT-GLAZE 4.7K JA 1/10W		R653	RGF2700JTCANL	MT-GLAZE 270 JA 1/10W	
R604	RGB5603JTBANL	MT-GLAZE 560K JA 1/4W		R654	RSXAV1R68JDAK	OXIDE-MT 0.68JB 1W	
R6040	RGF2202JTCANL	MT-GLAZE 22K JA 1/10W		R655	RGB10R0JTBANL	MT-GLAZE 10 JA 1/4W	
R6041	RGF1001JTCANL	MT-GLAZE 1K JA 1/10W		R656	RGF1200JTCANL	MT-GLAZE 120 JA 1/10W	
R6042	RGF1001JTCANL	MT-GLAZE 1K JA 1/10W		R658	RCA1005KPCANN	SOLID 10M KA 1/2W 	
R6043	RGF2202JTCANL	MT-GLAZE 22K JA 1/10W		R658	RCXLB106KZAN	SOLID 10M KA 1/2W 	
R6044	RGF1002JTCANL	MT-GLAZE 10K JA 1/10W		R659	RCA1005KPCANN	SOLID 10M KA 1/2W 	
R6045	RGF1001JTCANL	MT-GLAZE 1K JA 1/10W		R659	RCXLB106KZAN	SOLID 10M KA 1/2W 	
R6046	RGF1001JTCANL	MT-GLAZE 1K JA 1/10W		R667	RGF1001JTCANL	MT-GLAZE 1K JA 1/10W	
R6047	RGF1001JTCANL	MT-GLAZE 1K JA 1/10W		R680	RGB1002JTBANL	MT-GLAZE 10K JA 1/4W	
R6048	RGB1002JTBANL	MT-GLAZE 10K JA 1/4W		R6898	RGF2201FTCANL	MT-GLAZE 2.2K FA 1/10W	
R6049	RGF1002JTCANL	MT-GLAZE 10K JA 1/10W		R694	RGF1001JTCANL	MT-GLAZE 1K JA 1/10W	
R605	RGB4703JTBANL	MT-GLAZE 470K JA 1/4W		T601	1LB4L51B1210N	TRANS,POWER,PULSE 	
R6050	RGB1002JTBANL	MT-GLAZE 10K JA 1/4W		T602	1LB4L51B1200N	TRANS,POWER,PULSE 	
R6059	RGF1002JTCANL	MT-GLAZE 10K JA 1/10W		VA601	DVENE621D14AN	VARISTOR ENE621D-14A 	
R606	RGB3903JTBANL	MT-GLAZE 390K JA 1/4W		VA601	DVS14K385E2-N	VARISTOR 	
R6060	RGF2702JTCANL	MT-GLAZE 27K JA 1/10W		ZD1	DZUDZS27B---G	ZENER DIODE UDZS27B-TE-17	
R607	RGB2201JTBANL	MT-GLAZE 2.2K JA 1/4W		ZD2	DZUDZS13B---G	ZENER DIODE UDZS13B-TE-17	
R608	RGA2R20JTDANL	MT-GLAZE 2.2 JA 1/2W		ZD3	DZUDZS18B---G	ZENER DIODE UDZS18B-TE-17	
R609	RGK1000JTFANL	MT-GLAZE 100 JA 1/3W		ZD5	DZXLBZA36A--N	ZENER DIODE MTZJ36A	
R610	RDXLBB330JVAN	CARBON 33 JA 1/4W		ZD6	DZUDZS16B---G	ZENER DIODE UDZS16B-TE-17	
R610	RDXLBB330JXAN	CARBON 33JA 1/4W		PB601	1LG4B10Y0170B	PWB,KEY N5CV	
R611	RGF1001JTCANL	MT-GLAZE 1K JA 1/10W		PB601	1LG4B10Y01700	PWB,POWER N5AV+KEY(N5CV)	
R6111	RGB2200JTBANL	MT-GLAZE 220 JA 1/4W					
R612	RGF4701FTCANL	MT-GLAZE 4.7K FA 1/10W					
R614	RGF3301JTCANL	MT-GLAZE 3.3K JA 1/10W					
R615	RGF8201FTCANL	MT-GLAZE 8.2K FA 1/10W					
R616	RGF1001FTCANL	MT-GLAZE 1K FA 1/10W					
R617	RGF3903JTCANL	MT-GLAZE 390K JA 1/10W					
R618	RGB1002JTBANL	MT-GLAZE 10K JA 1/4W					
R619	RGF8201FTCANL	MT-GLAZE 8.2K FA 1/10W					
R620	RGF1801FTCANL	MT-GLAZE 1.8K FA 1/10W					
R621	RGB7503JTBANL	MT-GLAZE 750K JA 1/4W					
R622	RGB7503JTBANL	MT-GLAZE 750K JA 1/4W					
R623	RSXLB2563JXAS	OXIDE-MT 56K JA 2W					
R623	RSXLB2563JYAS	OXIDE-MT 56KJA 2W					
R623	RSXLB2563JYBS	OXIDE-MT 56KJA 2W					
R623	RS25602JGDAGN	MT-GLAZE 56K JA 2W					
R623	RS25602JGDANN	OXIDE-MT 56K JA 2W					
R624	RGB7503JTBANL	MT-GLAZE 750K JA 1/4W					

Printed Wiring Board

MAIN BOARD (Parts Side)

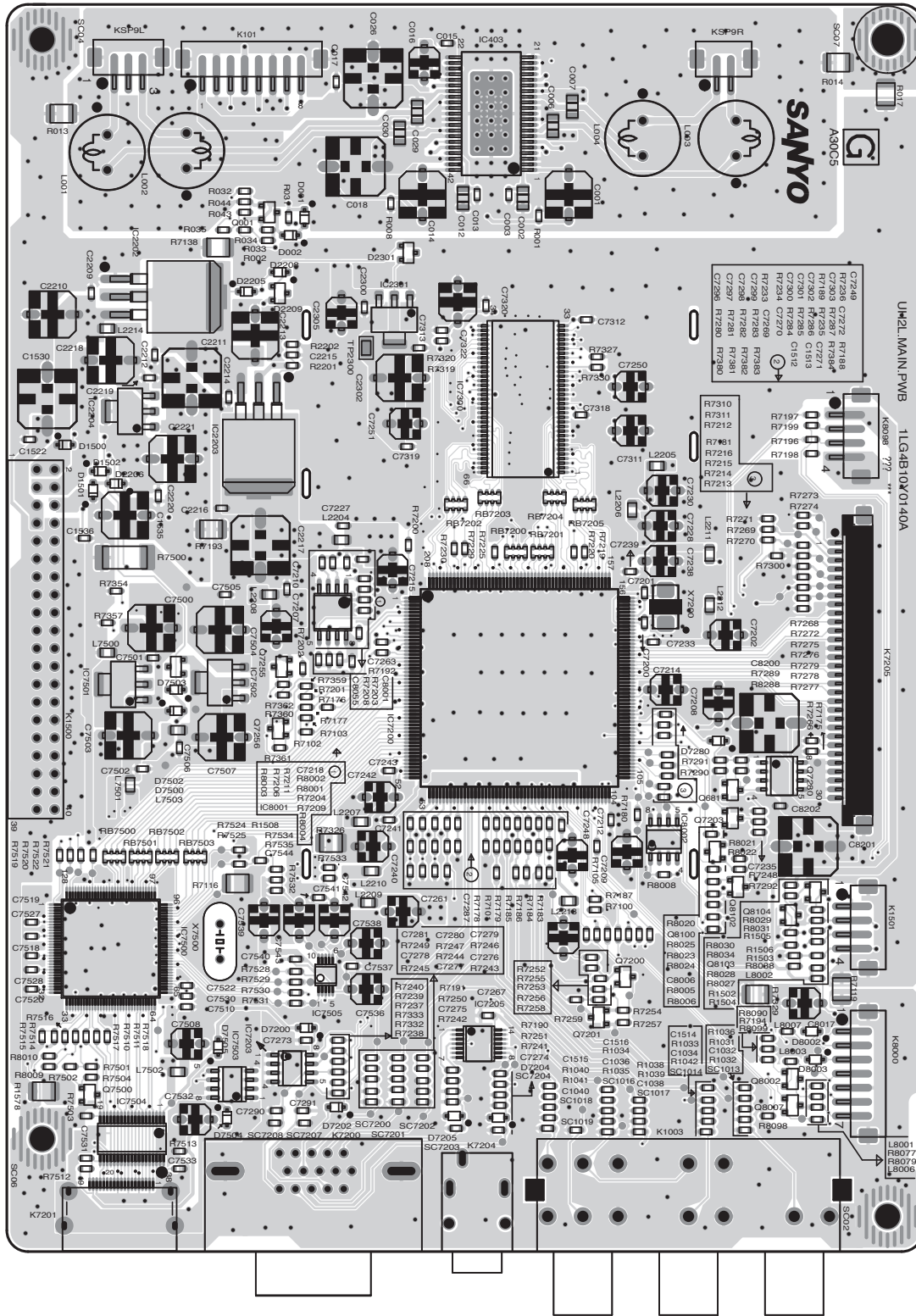

Printed Wiring Board

MAIN BOARD (Solder Side)

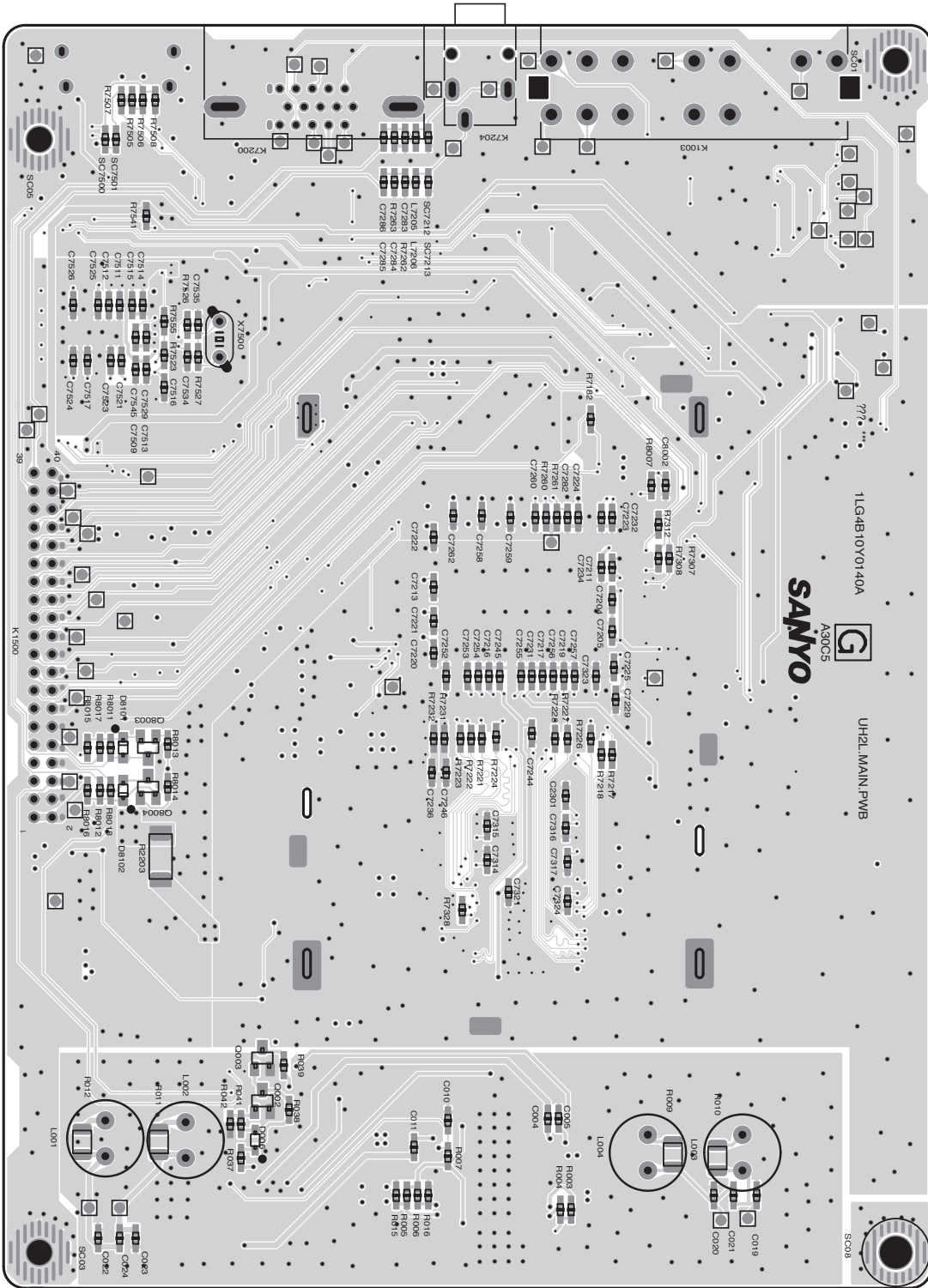

Printed Wiring Board

SUB BOARD (Parts Side)

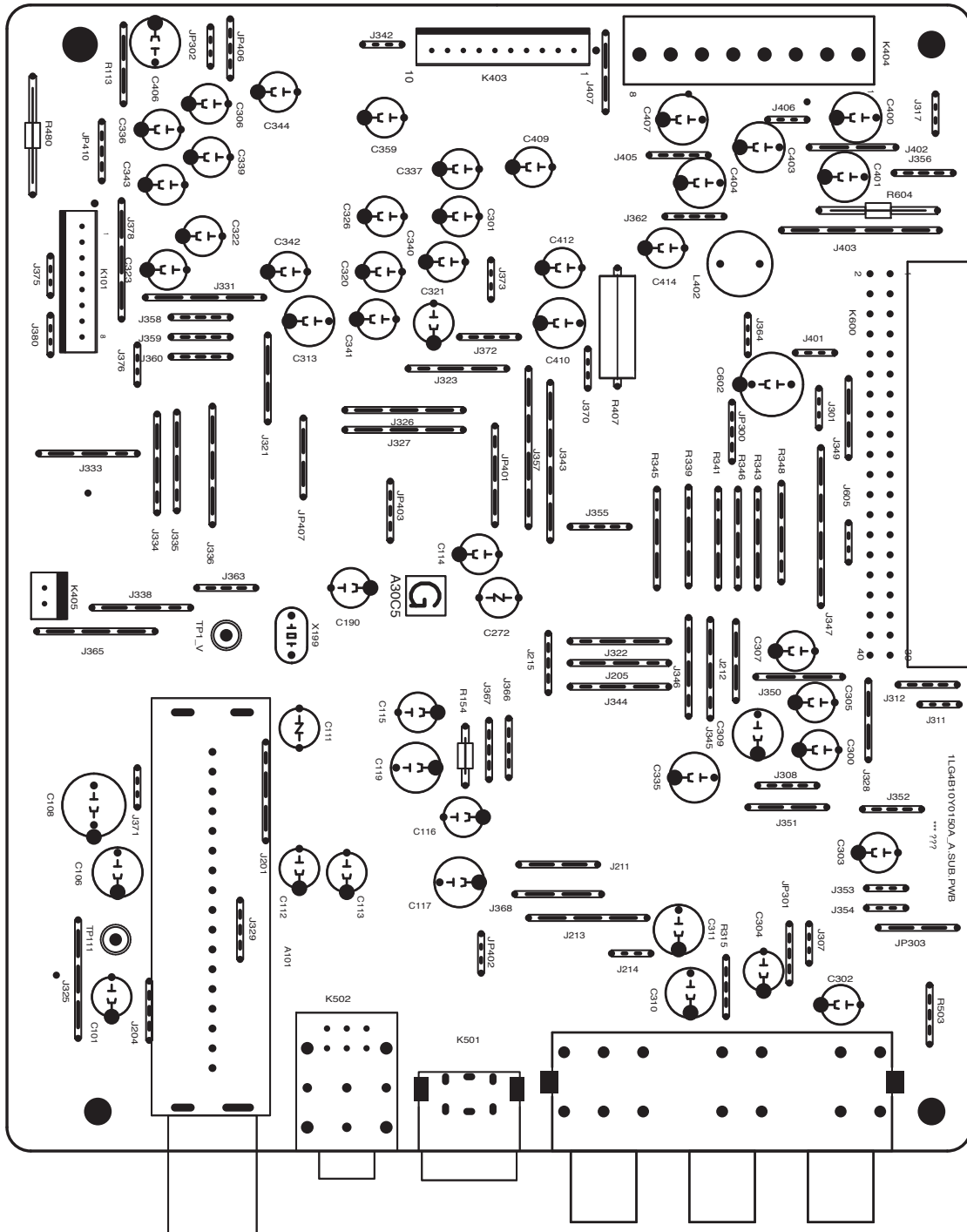

Printed Wiring Board

POWER BOARD (Parts Side)

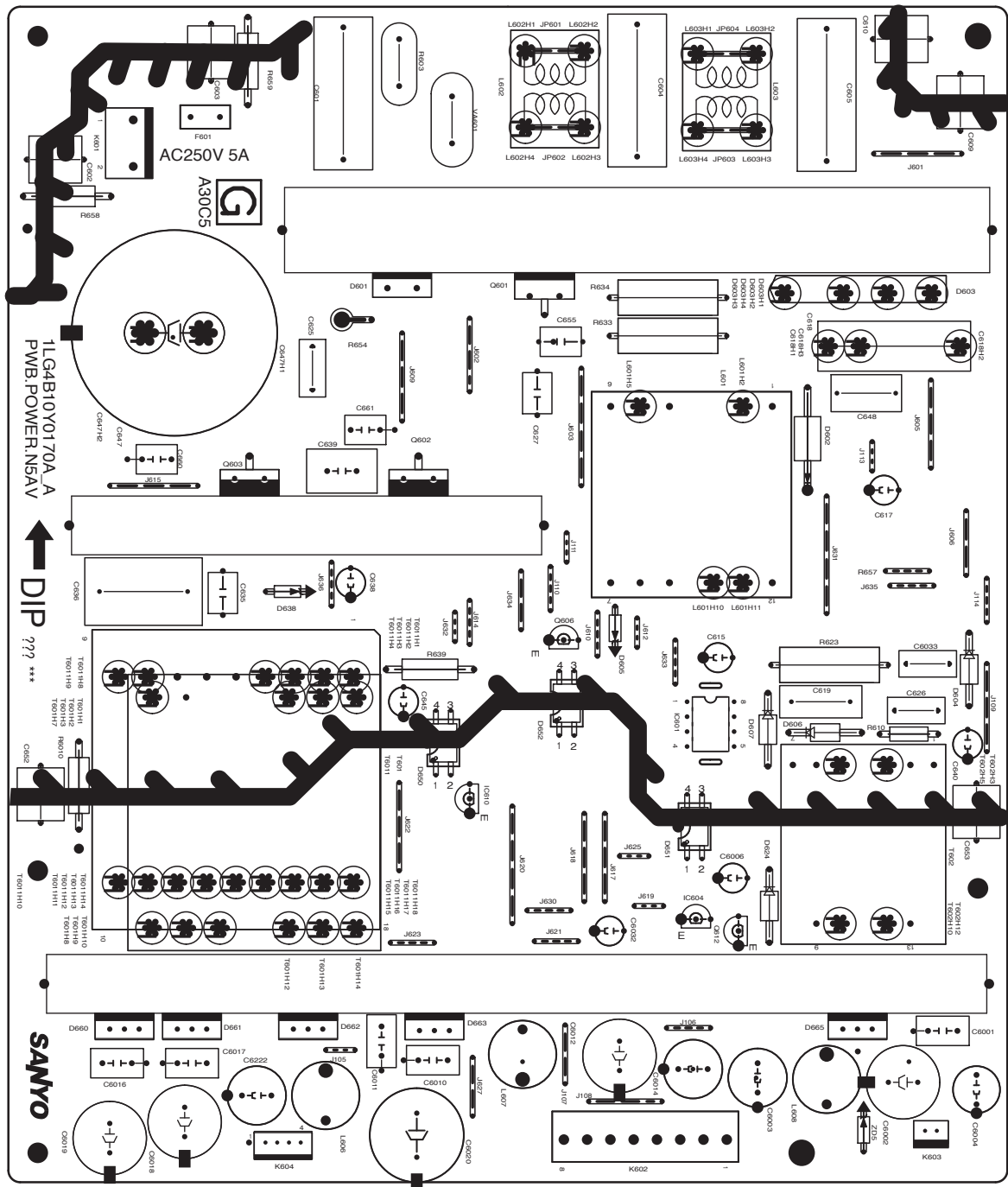

Printed Wiring Board

POWER BOARD (Solder Side)

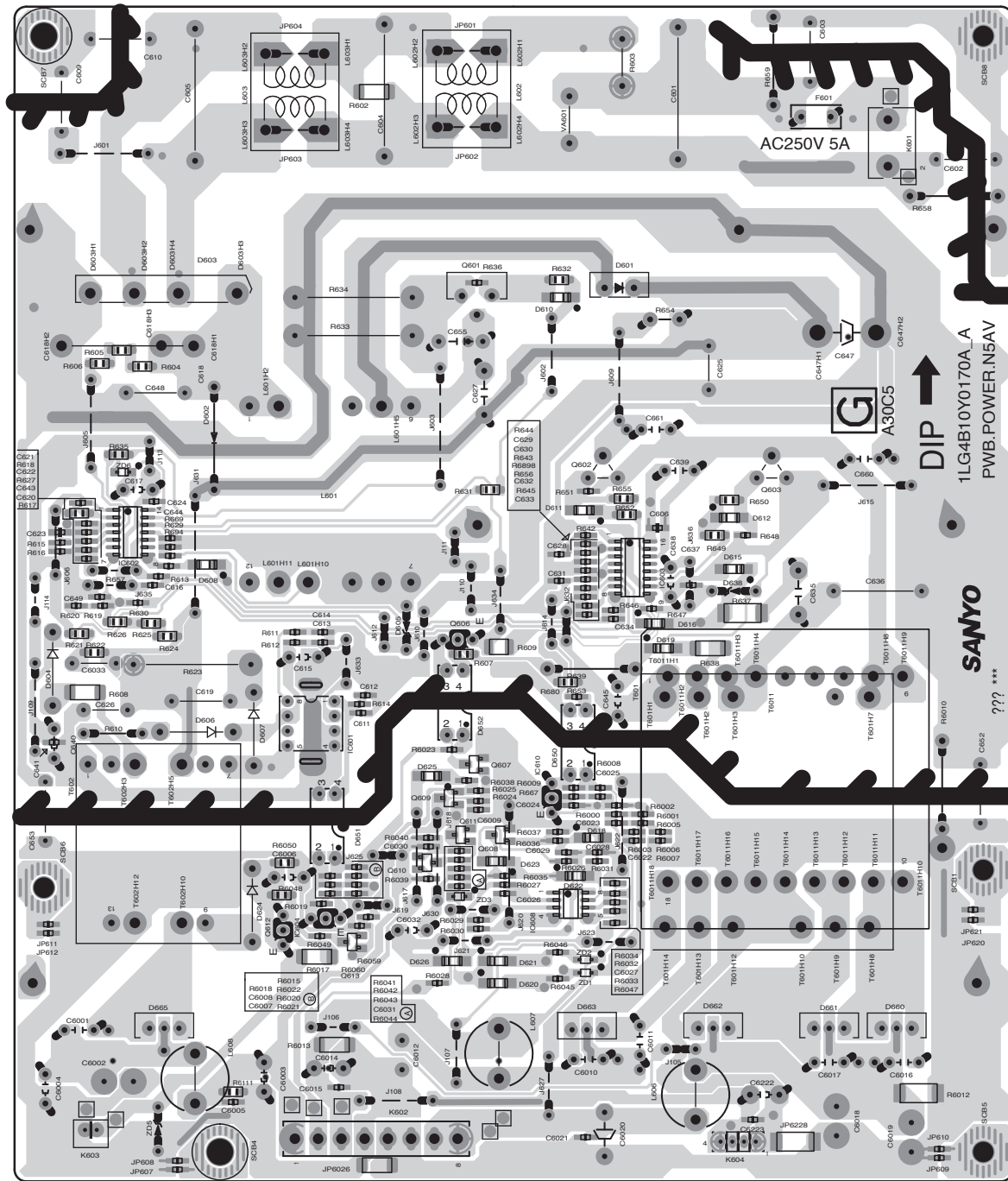

Printed Wiring Board

KEY BOARD (Parts Side)

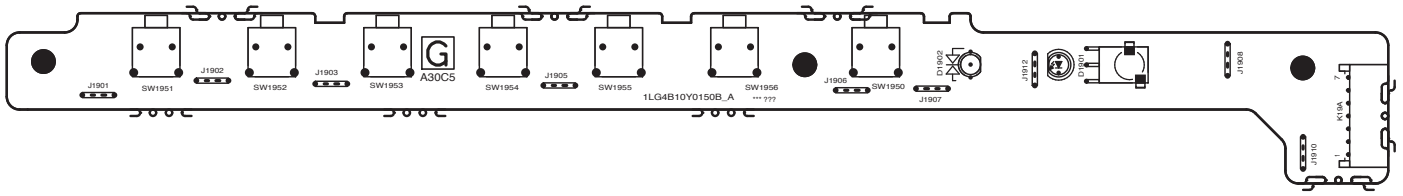

KEY BOARD (Solder Side)

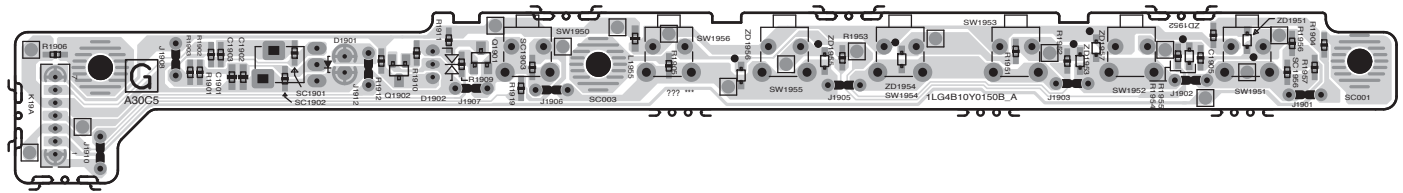

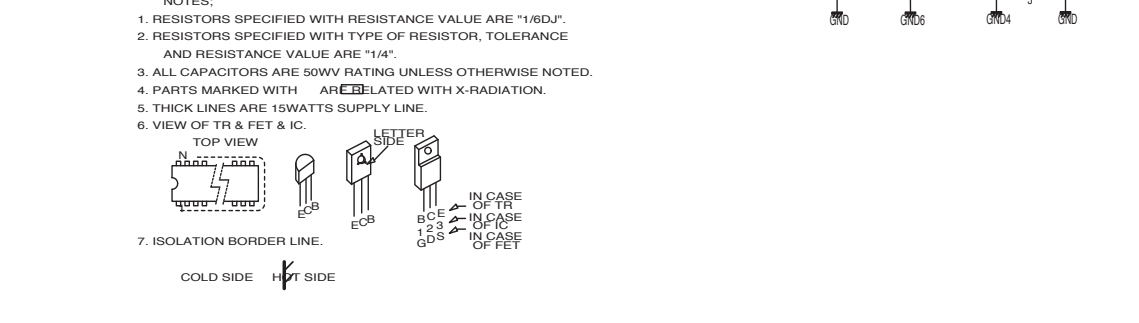
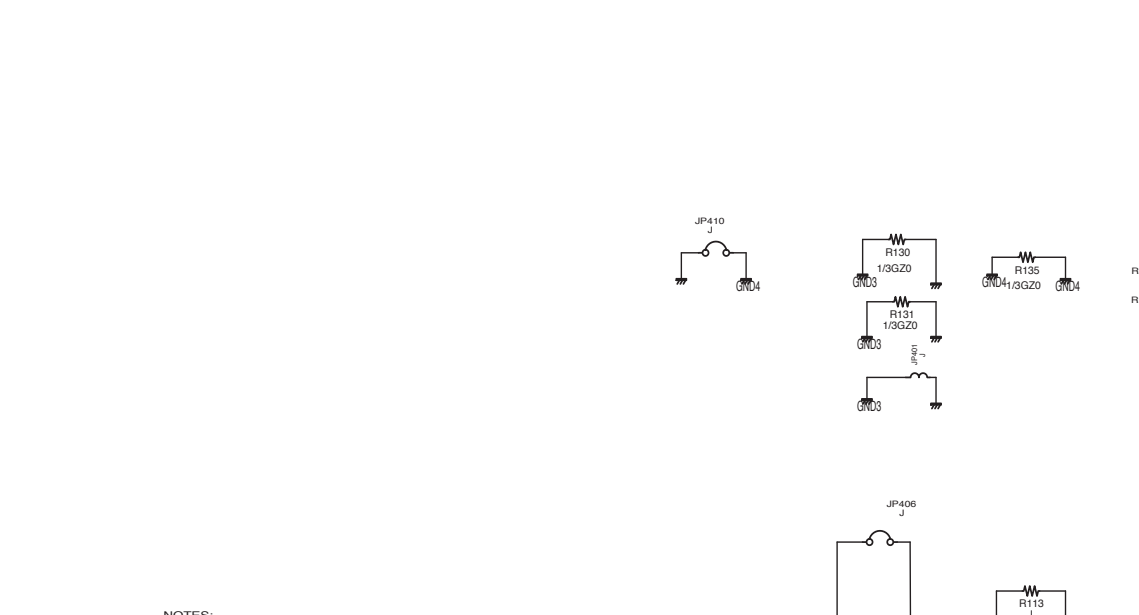
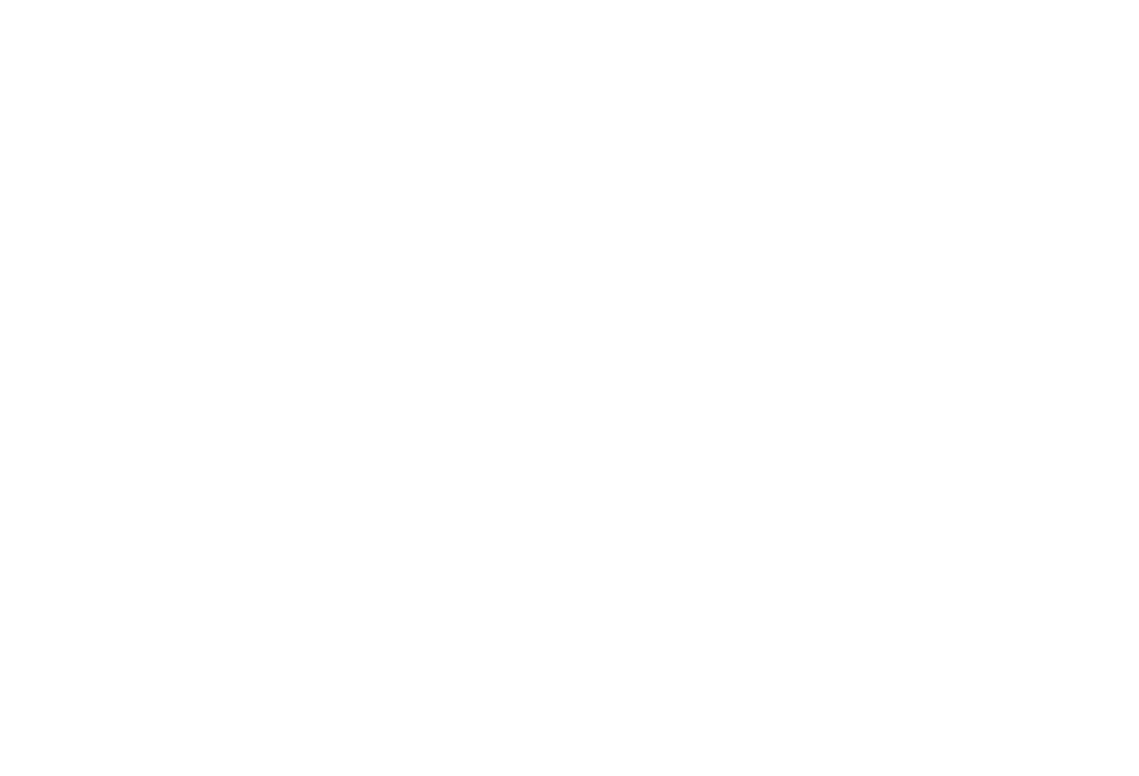
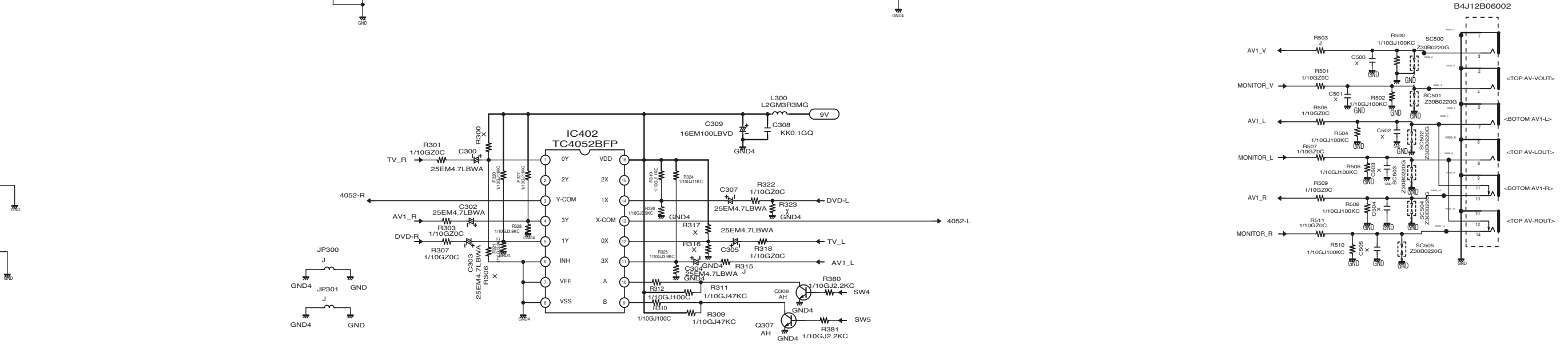
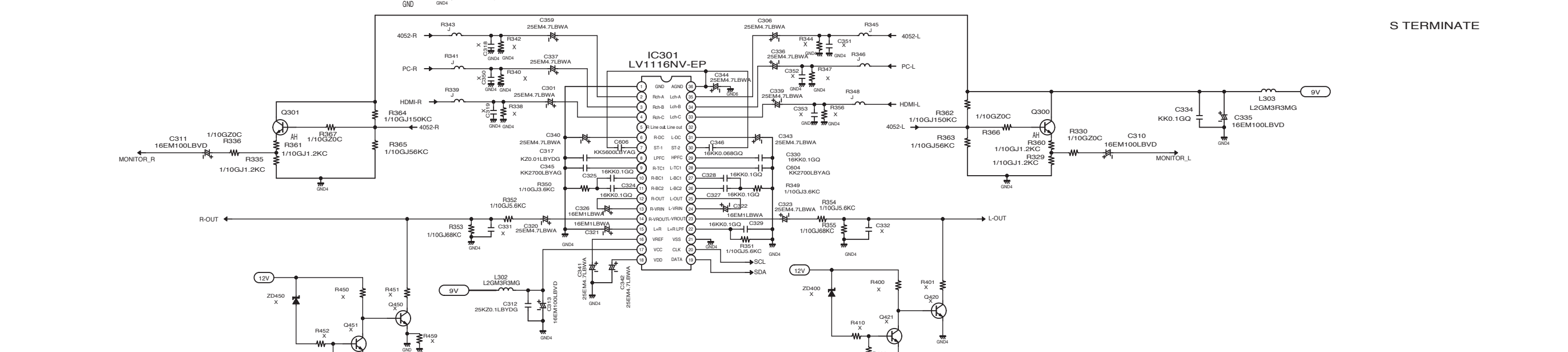
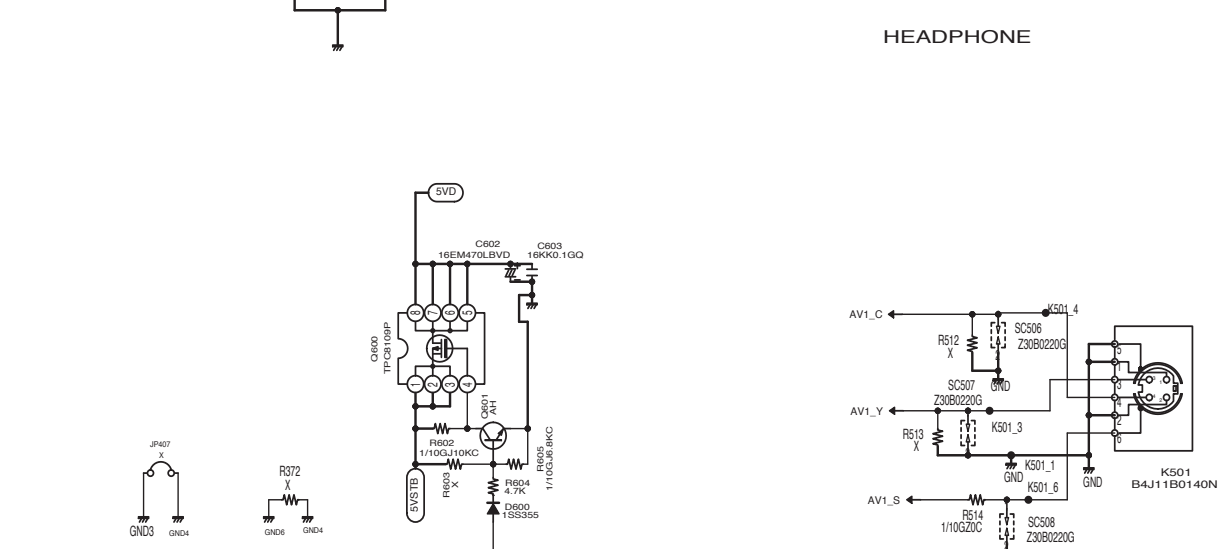
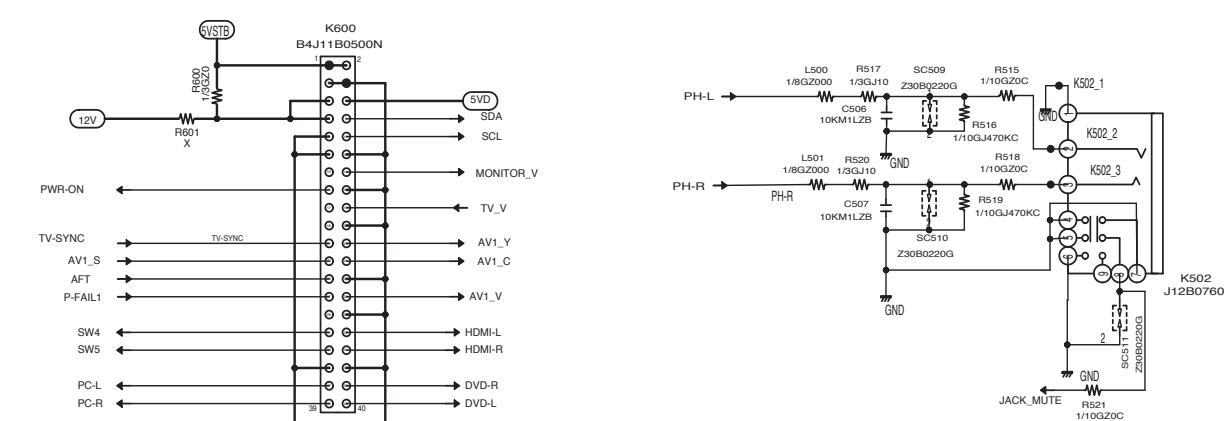
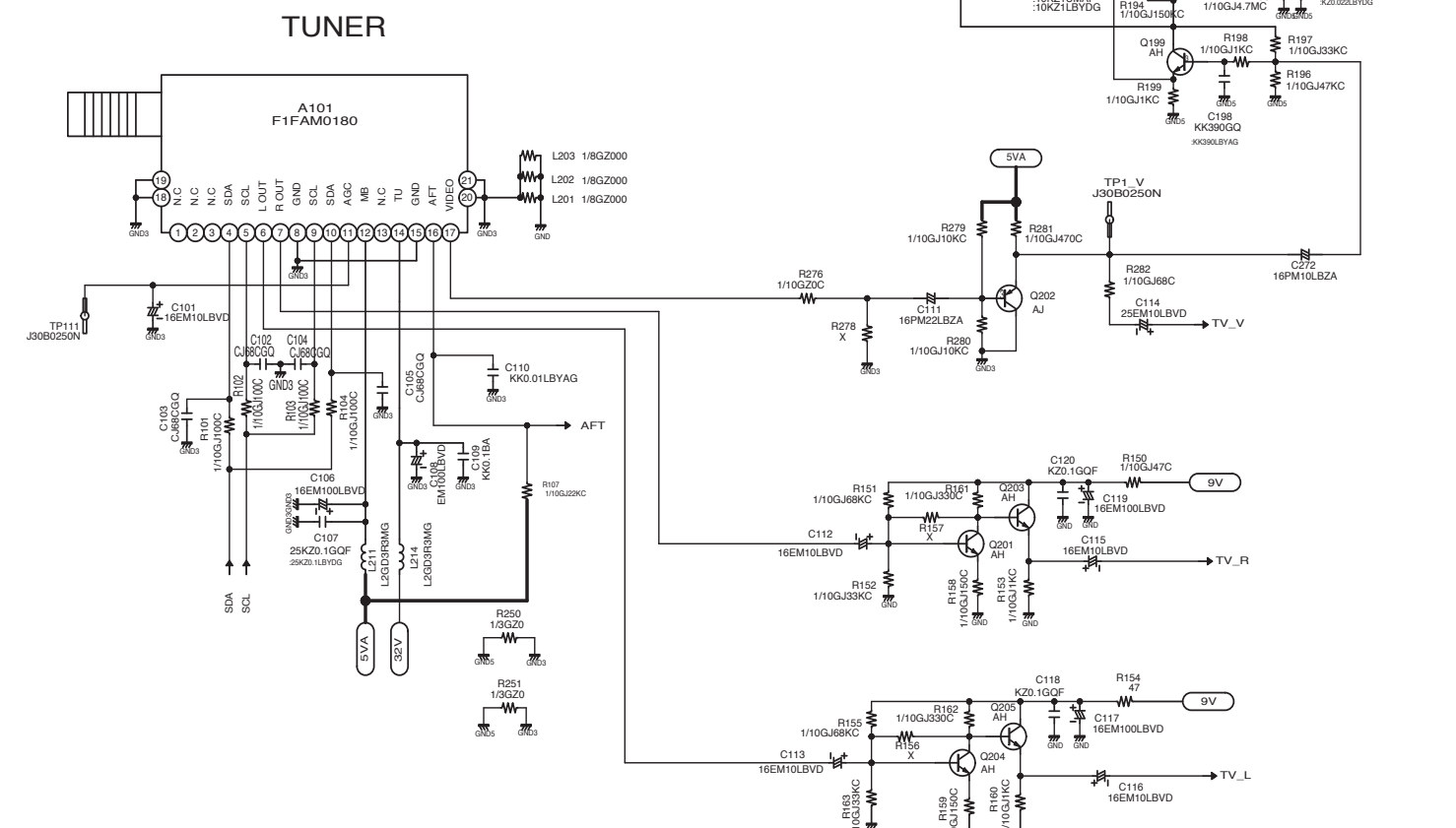
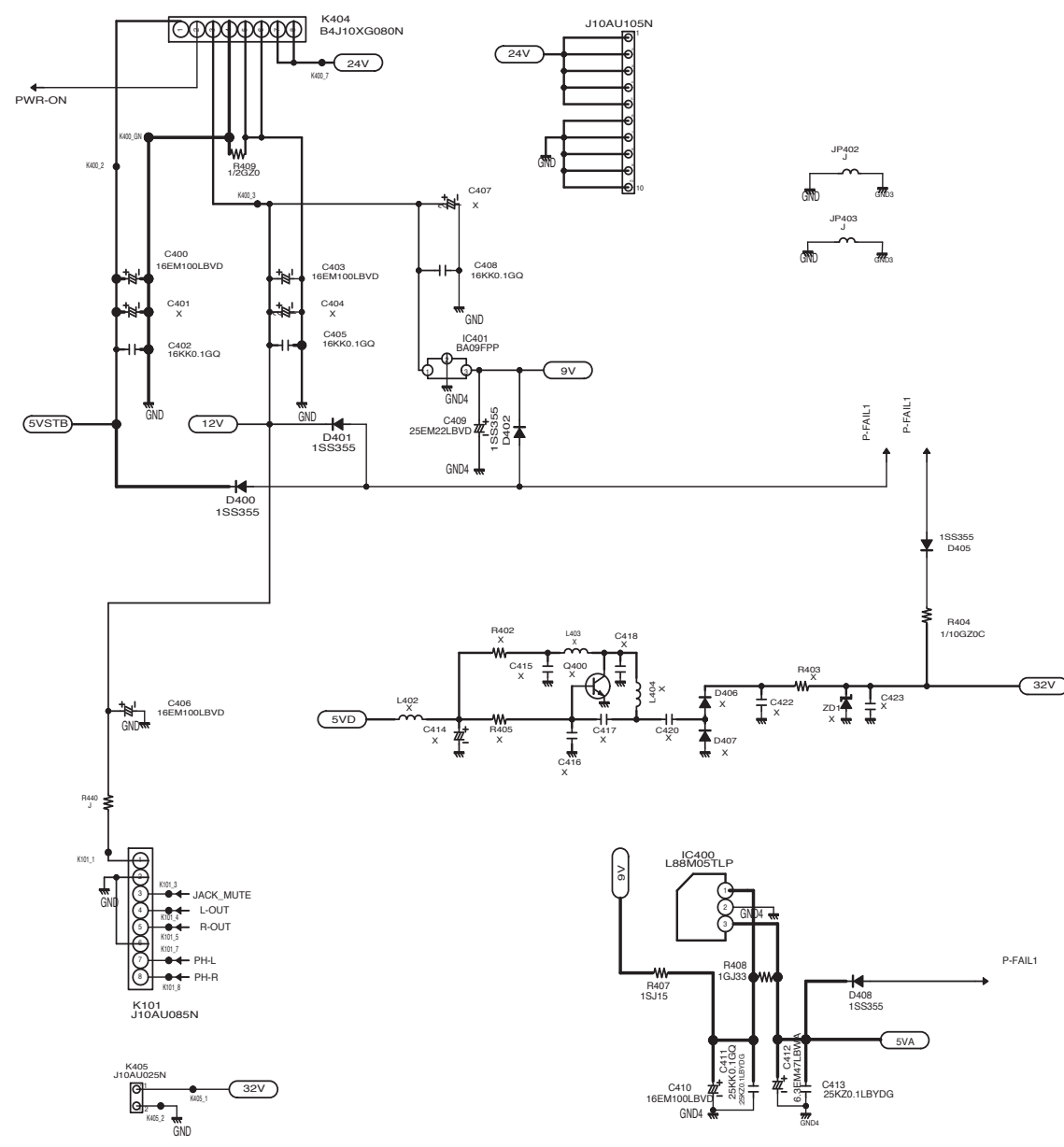

NOTES:
 1. RESISTORS SPECIFIED WITH RESISTANCE VALUE ARE "1/160J".
 2. RESISTORS SPECIFIED WITH TYPE OF RESISTOR, TOLERANCE AND RESISTANCE VALUE ARE "1/4".
 3. ALL CAPACITORS ARE 50VV RATING UNLESS OTHERWISE NOTED.
 4. PARTS MARKED WITH ARE RELATED WITH X-RADIATION.
 5. THICK LINES ARE 15WATTS SUPPLY LINE.
 6. VIEW OF TS & FET & IC.
 7. ISOLATION BORDER LINE.



